

# IDX4RAIL – KONSOLIDIERUNG UND STANDARDISIERUNG DER INFRASTRUKTUR- DATENMODELL- UND –SCHNITTSTELLEN- LANDSCHAFT IM STRASSENBAHN- UND STADTBAHNBEREICH

Gefördert durch:



Bundesministerium  
für Verkehr

aufgrund eines Beschlusses  
des Deutschen Bundestages

IDX4rail Datenmodell Beta 3

**IDX4rail**



# IDX4rail Datenmodell Beta 3



## Agenda

- Gleisgeometrie □ Track Geometry
- Bahnübergang □ Level Crossing
- Weiche □ Switch
- Gleisbett □ Track Bed
- Zustandsdaten □ Survey Data
- Instandhaltungsdaten □ Maintenance Data

# Track Geometry

- Horizontal alignment
- Gradients
- Superelevation

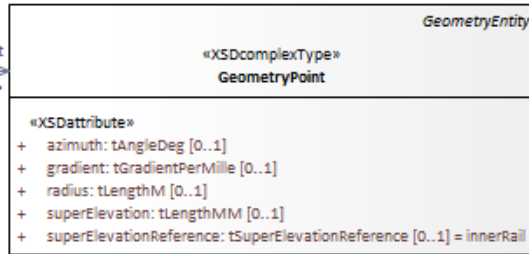
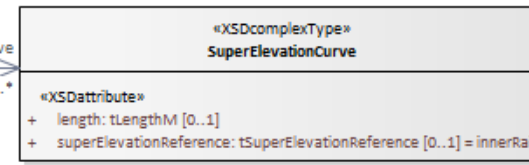
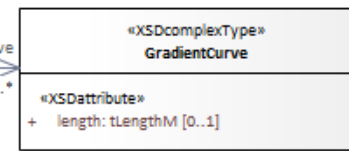
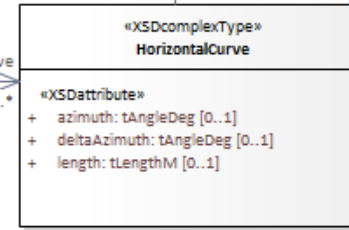
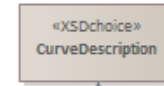
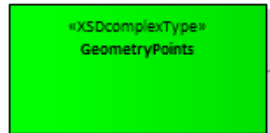
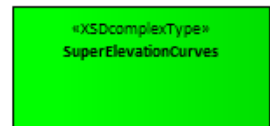
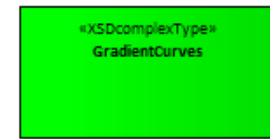
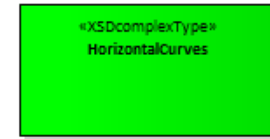
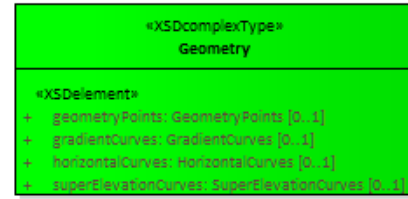

Removed radius. For some of the elements one needs more than one radius, for others no radius is needed. When refactoring curve descriptions to a switch the right parameters are supposed to go where they belong.

deltaAzimuth is probably not necessary here. Its redundant given the other information.

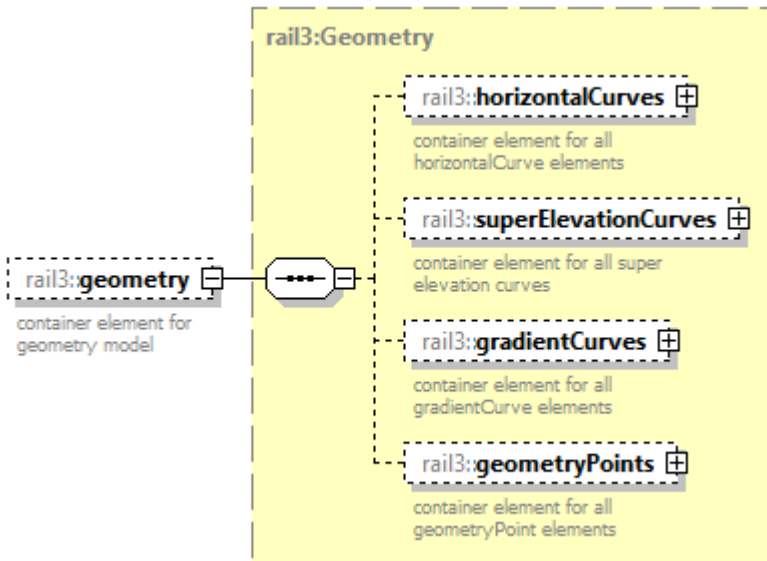
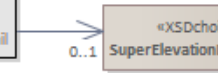
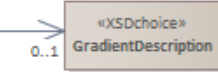
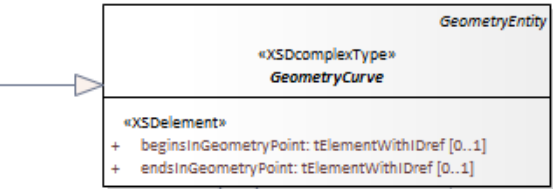

The specified superelevation is to be understood like this:

If the reference is middle, then the specified superelevation is applied to the one rail as positive value and the other as negative.

If the reference is innerRail, then the superElevation of the outerRail is specified in relation to the innerRail. If the innerRail has a superElevation specified at that point the specified superElevation is considered based on the non-elevated innerRail.

If the reference is outerRail, then the superElevation of the innerRail is specified like above, but vice versa.

# Horizontal Curves

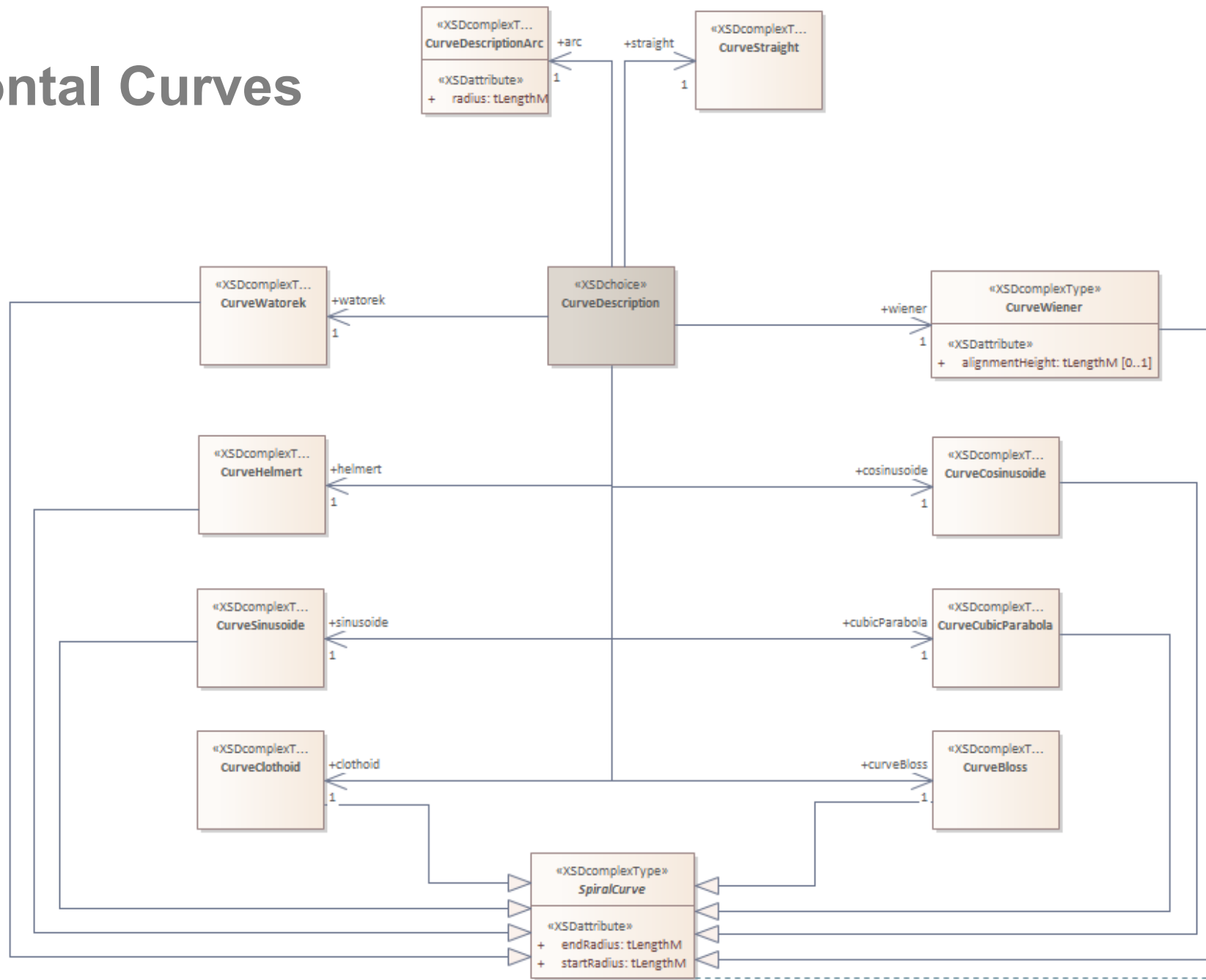

It is debatable if the radius should actually be a curvature. Curvature is defined as  $1/\text{radius}$ . The benefit would be that transitional curves between a straight line and an arc could be described more easily and mathematically correct, as the curvature of a straight line is 0 while the radius of a straight line is infinite. Drawback probably is the possible loss of precision when working with very small floating point numbers.

# Gradient Curves

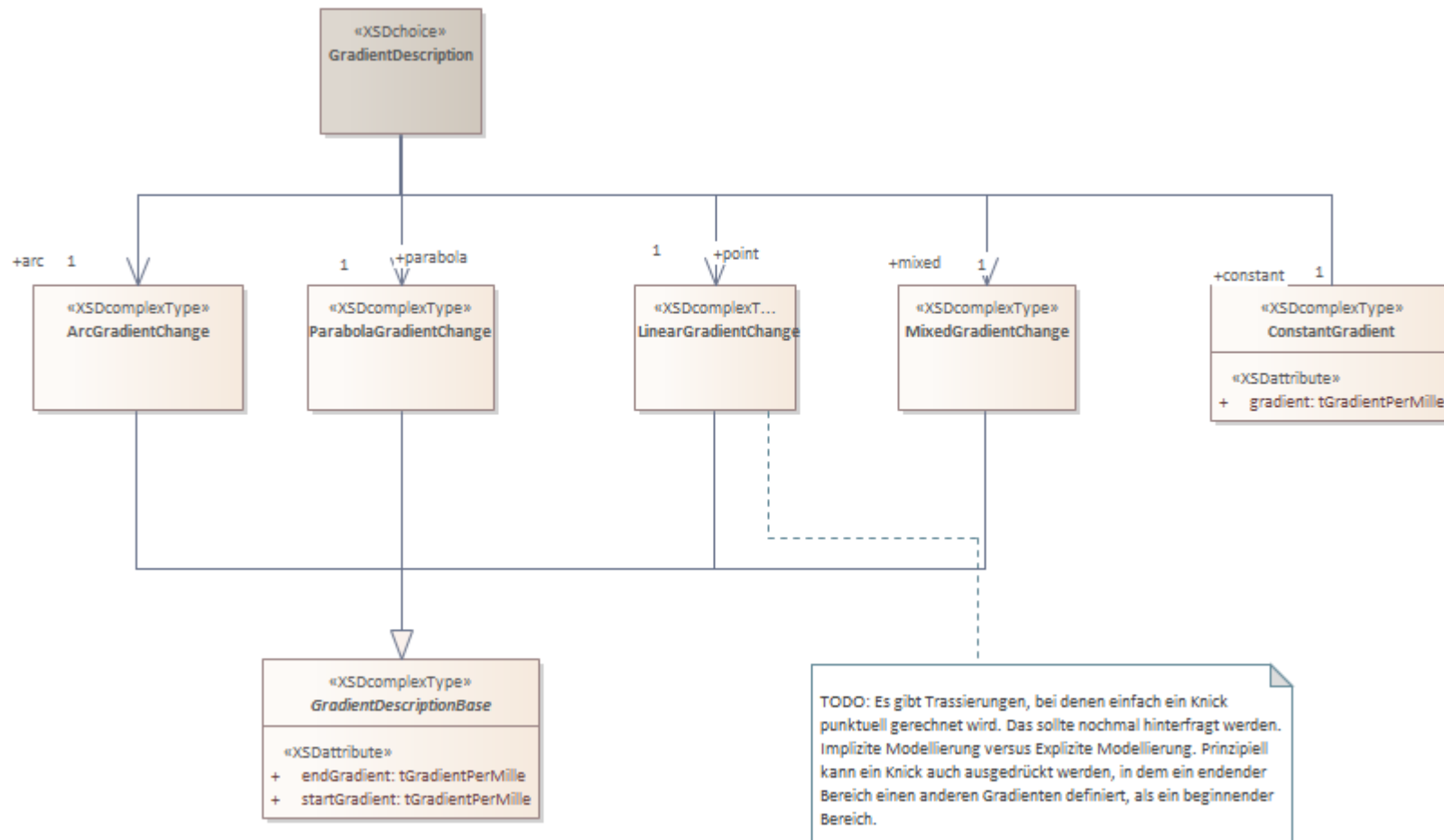

rail3:gradientCurve 1..∞  
with a gradientCurve the ascent and descent of a track can be described.

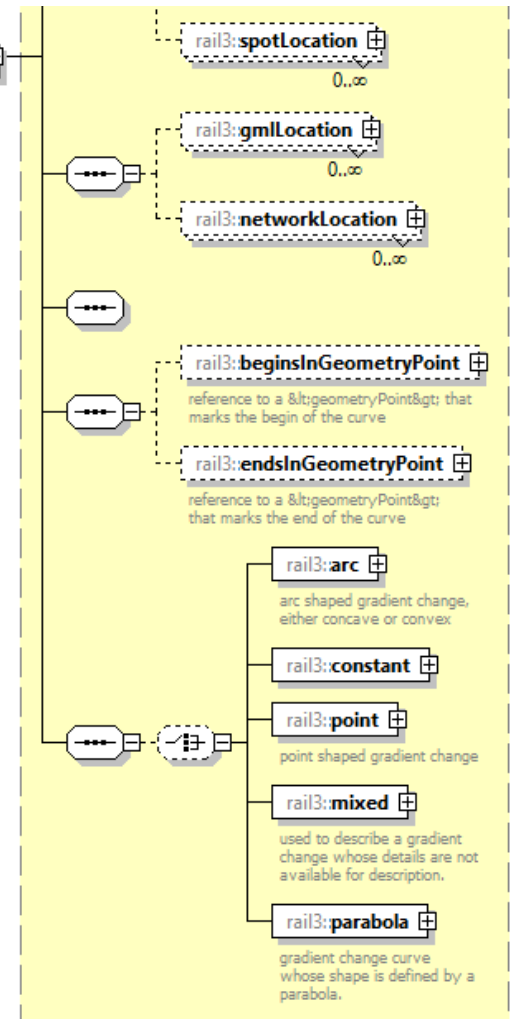

# Superelevation Curves

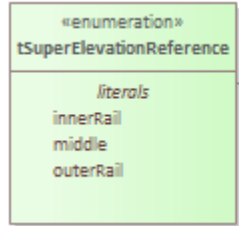
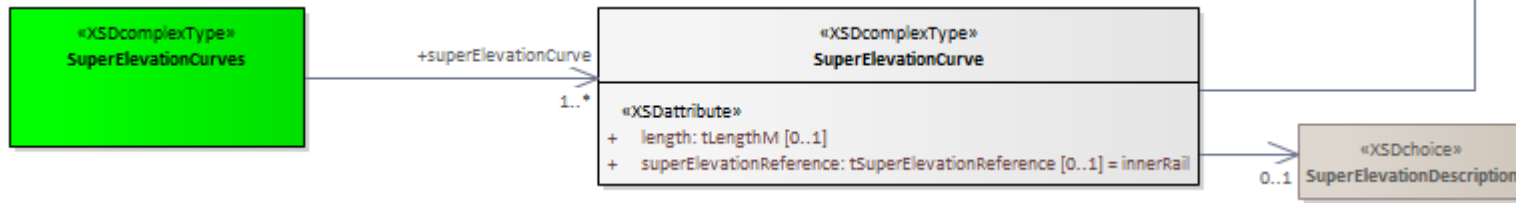

Should this be inner and outer or rather left and right? This gets tricky when looking at overlapping ramps on both rails (Gleisschere).

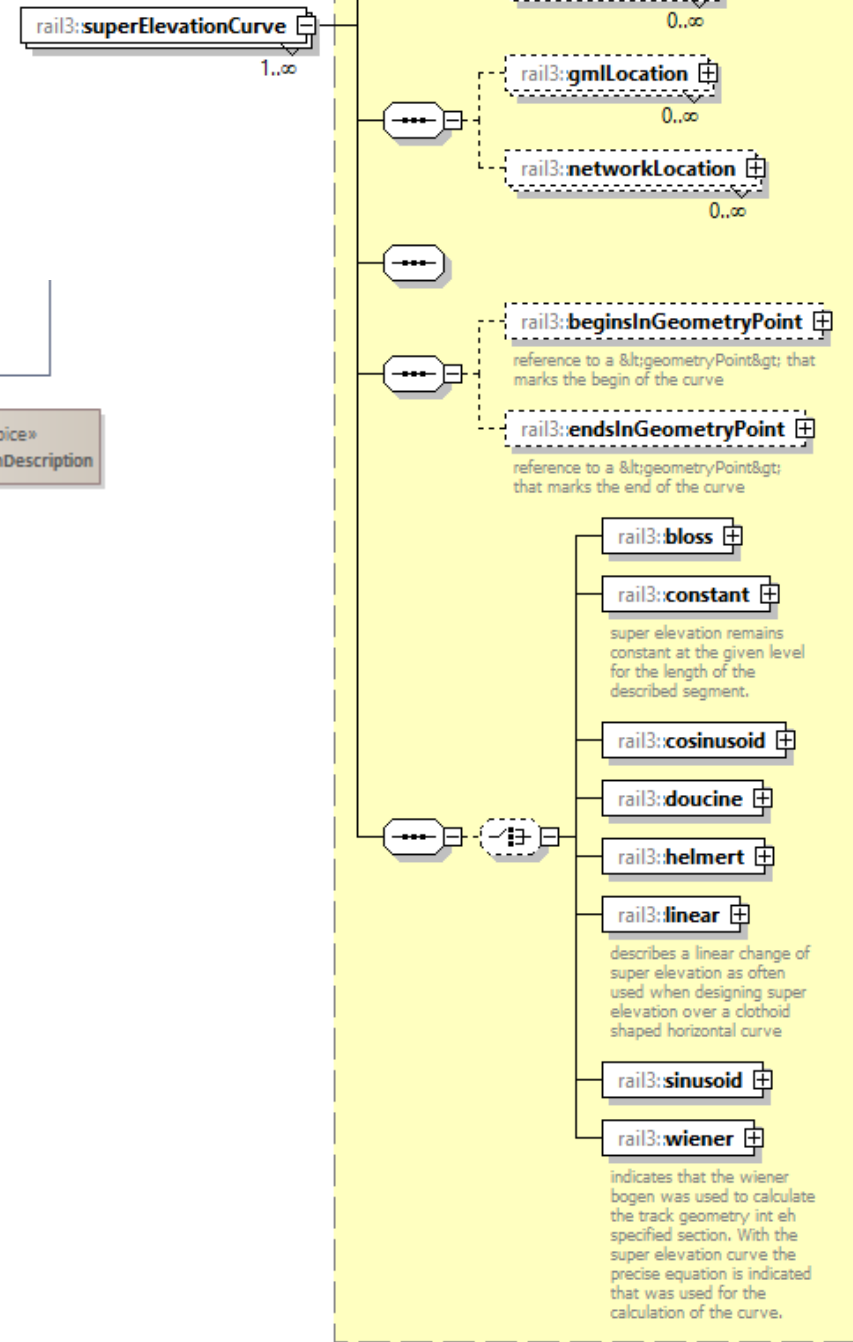
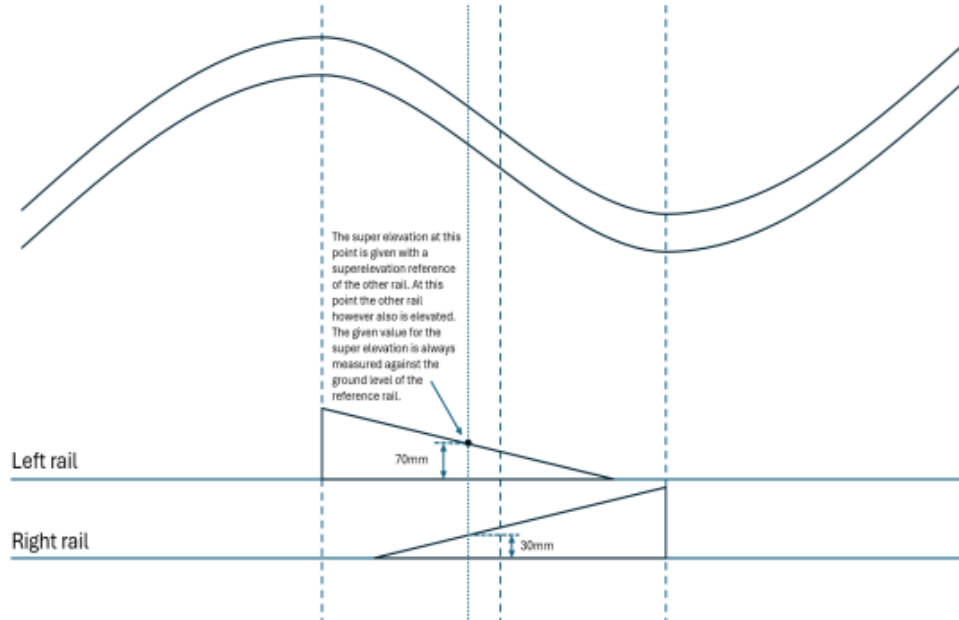

# Superelevation Curves

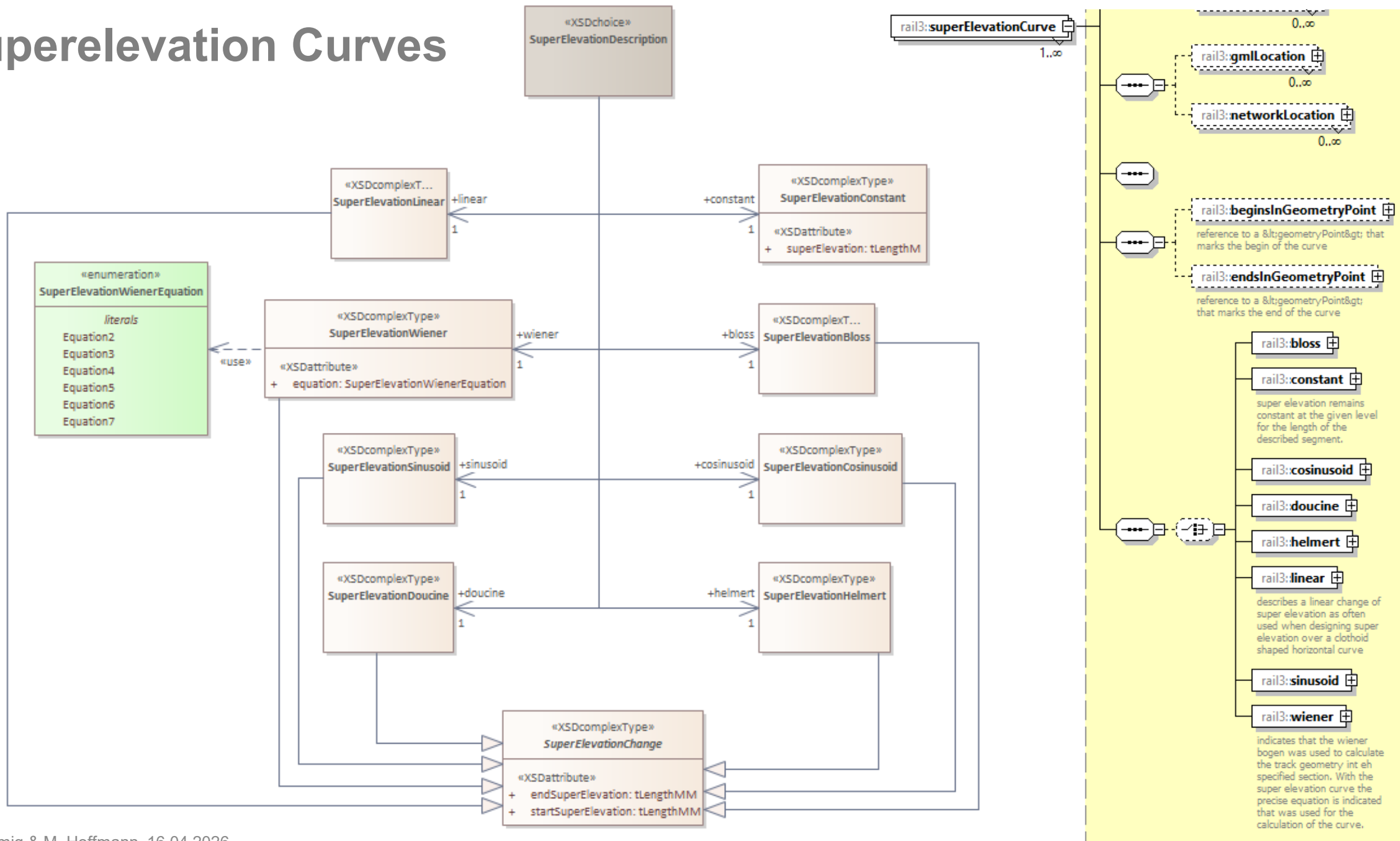

# Level Crossing

- Extending level crossing model:
  - Building authority (de: Baulasträger)
  - Types of railway crossings (permission)

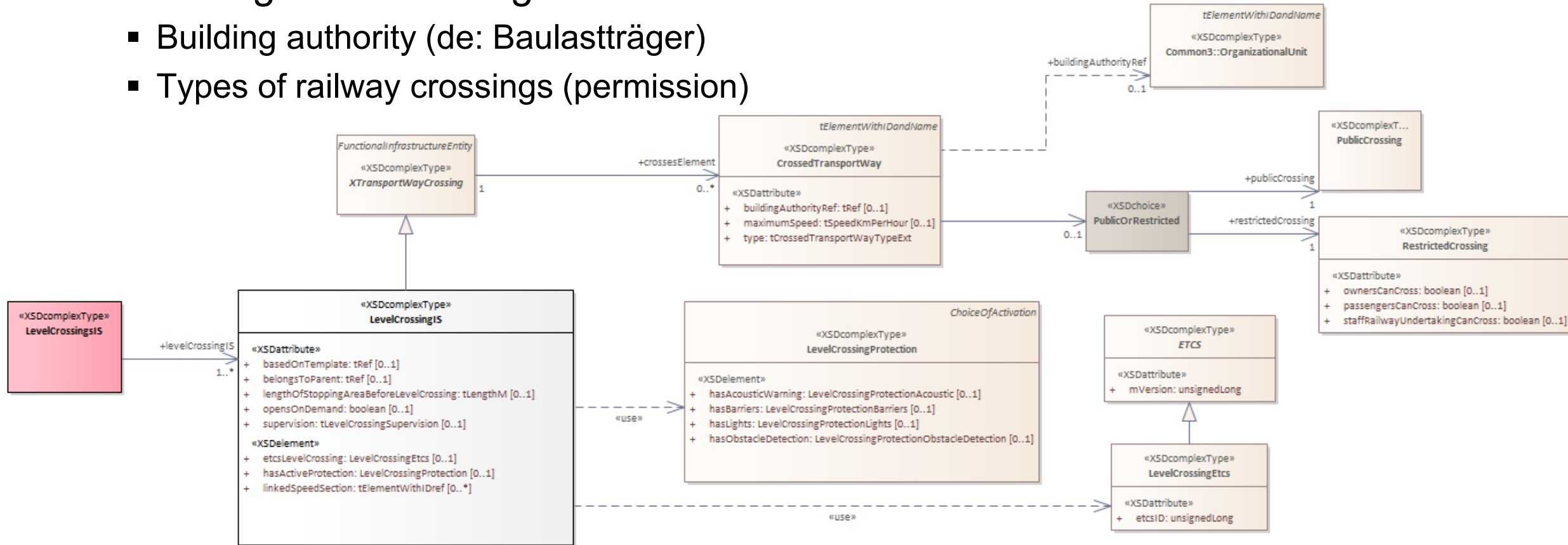

# Level Crossing

- Extending level crossing model:
  - Technical protection systems

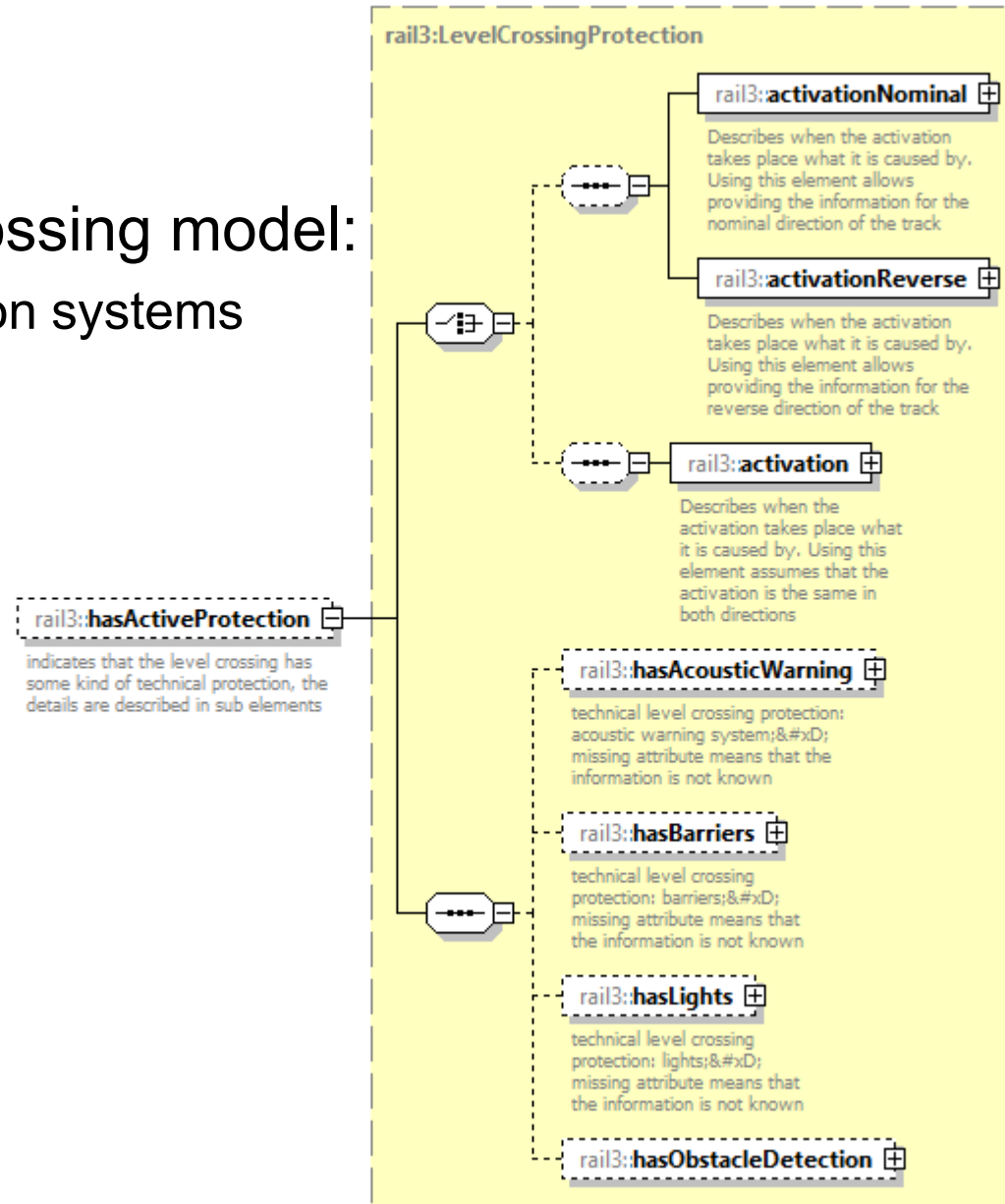

# Level Crossing

- Extending level crossing model:
  - Technical protection systems

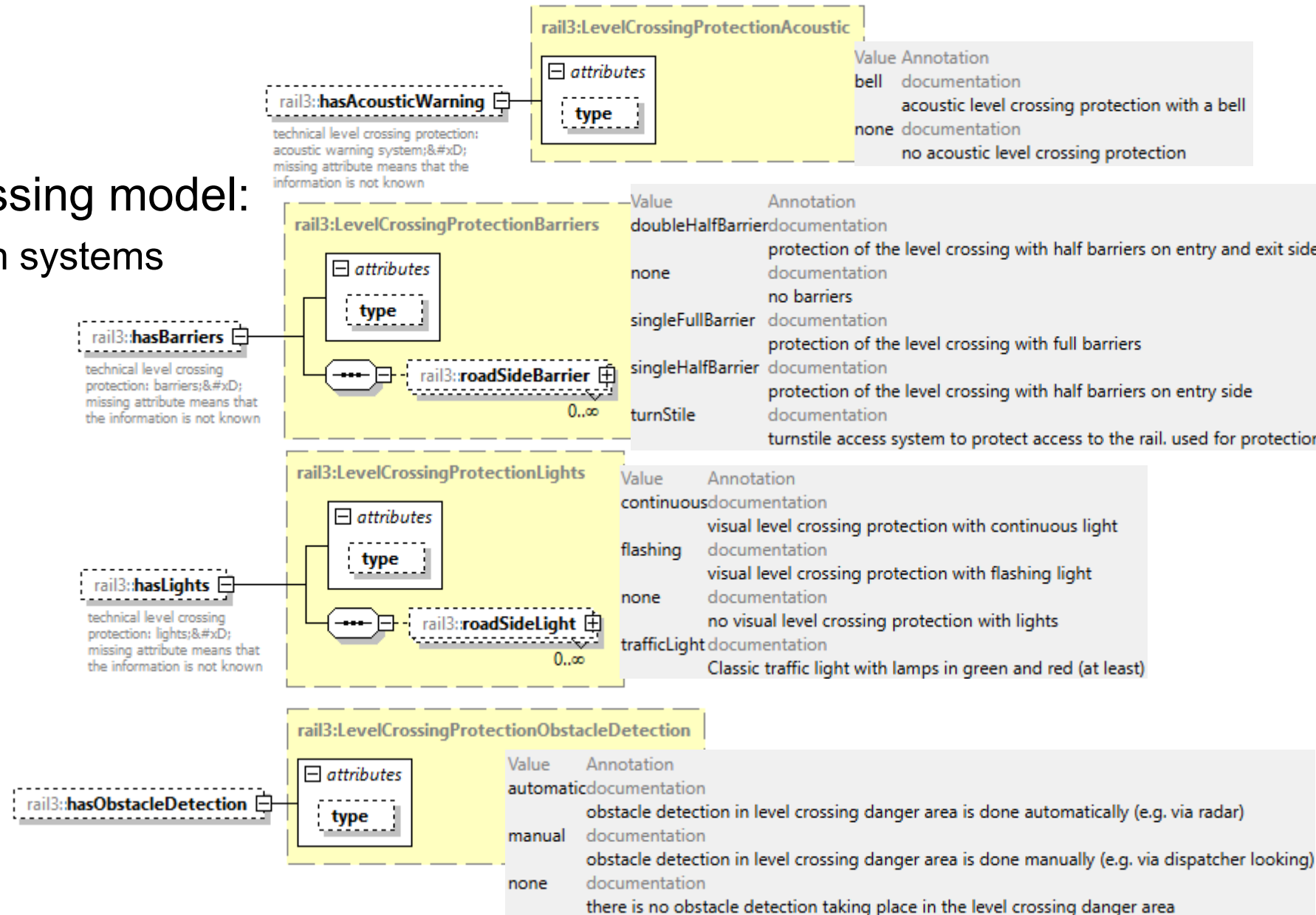

# Level Crossing

- Extending level crossing model:
  - Technical protection systems

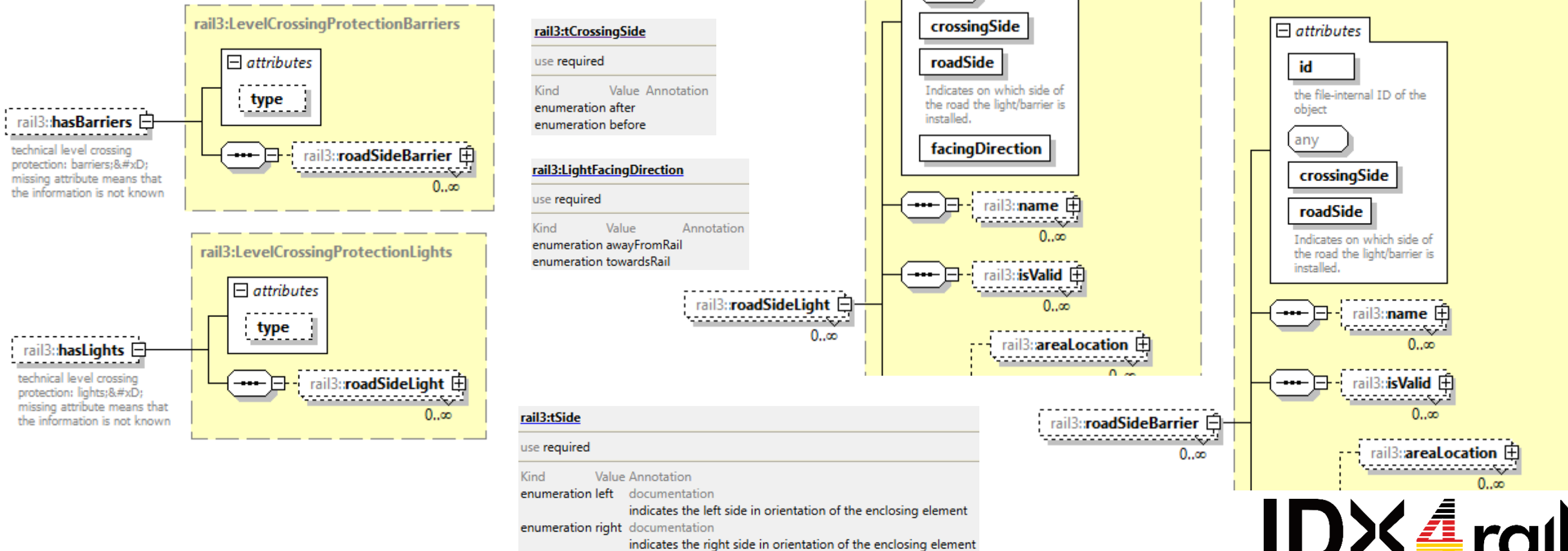

# Level Crossing

- Extending level crossing model:
  - Technical protection systems

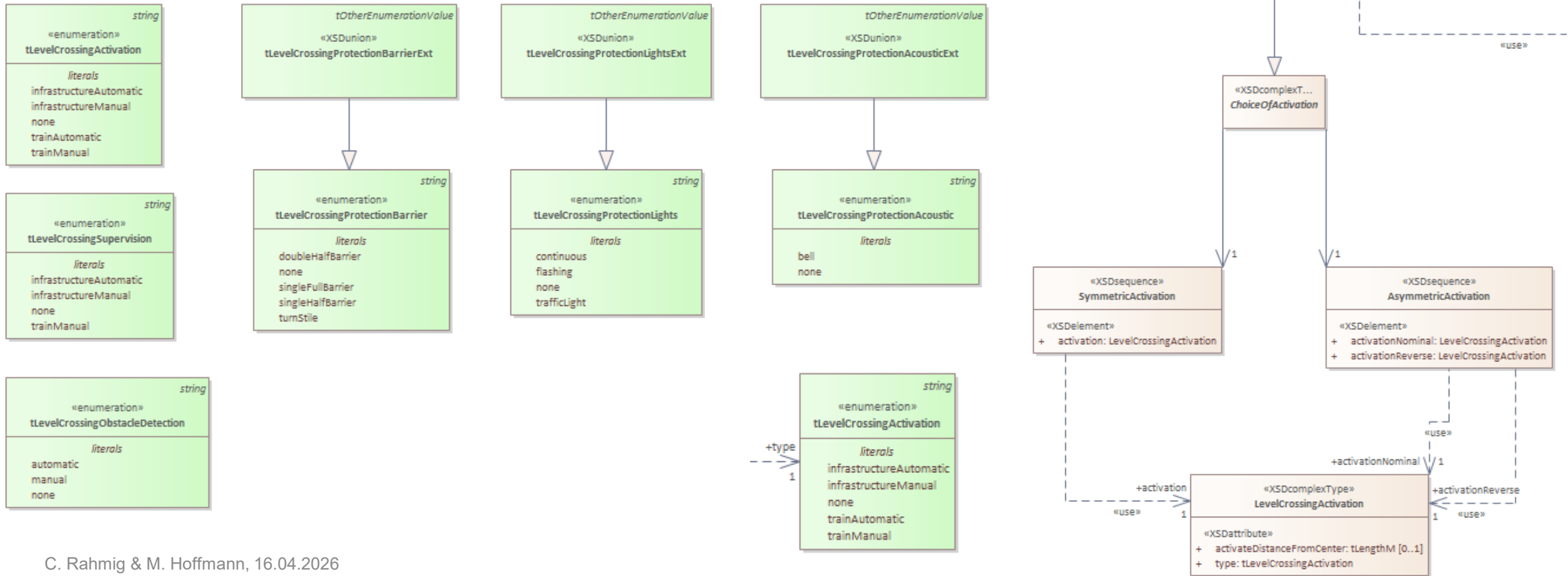

# Switch

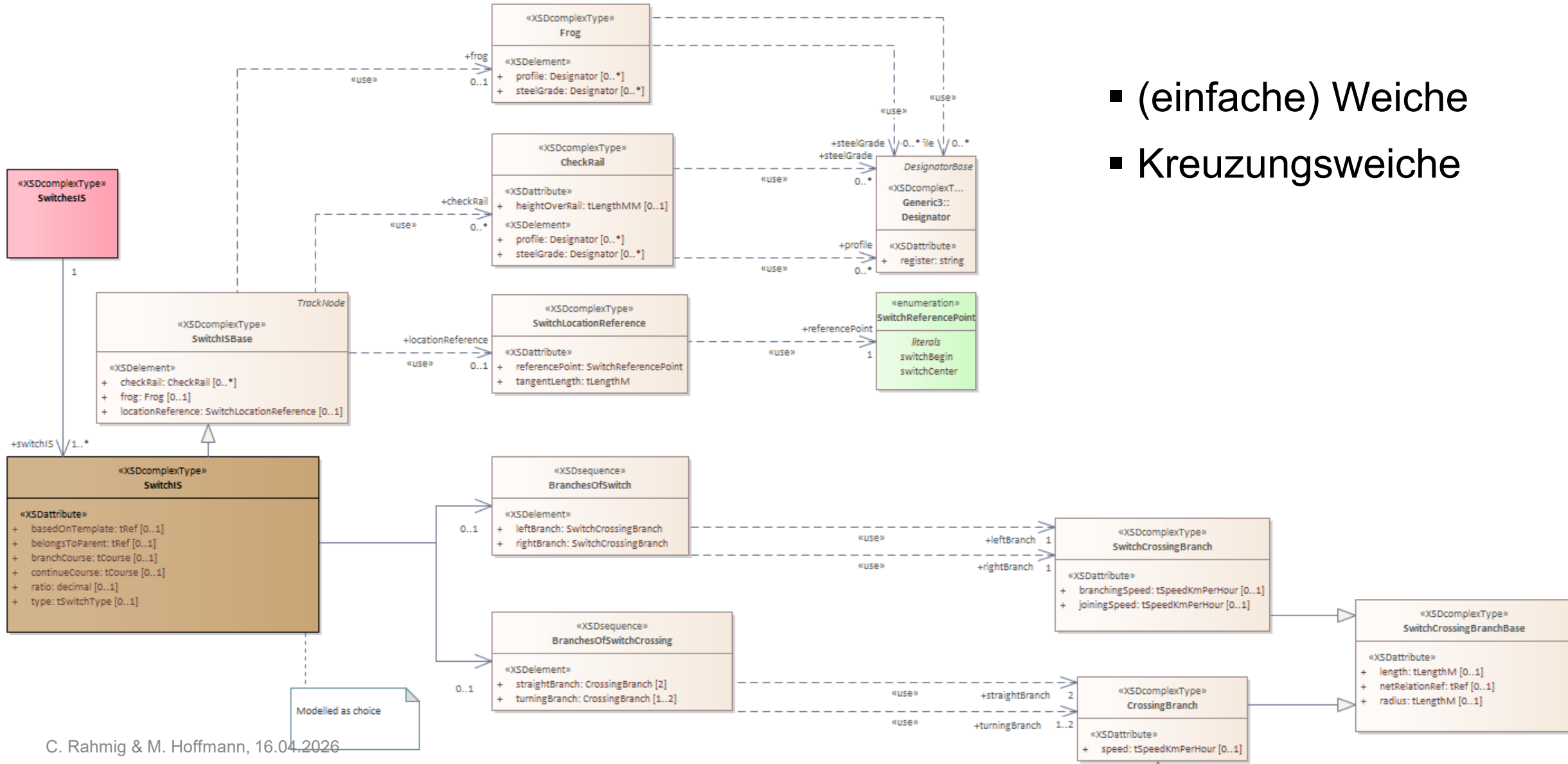

- (einfache) Weiche
- Kreuzungsweiche

Modelled as choice

# Switch

- Weichen-Gleise
  - Für einfache Weichen
  - Für Kreuzungsweichen

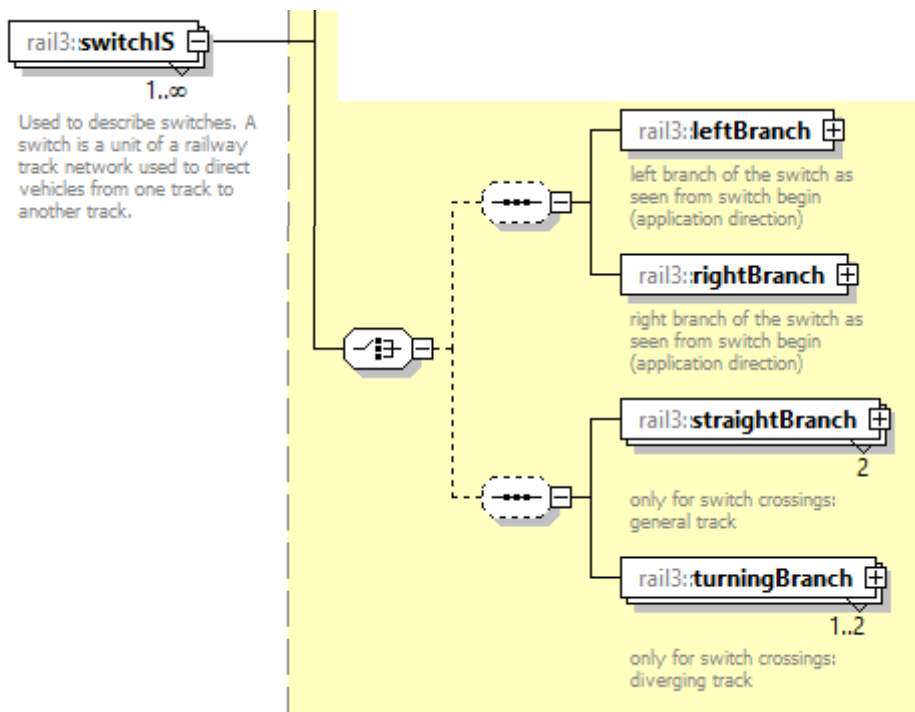

**rail3:leftBranch**  
left branch of the switch as seen from switch begin (application direction)

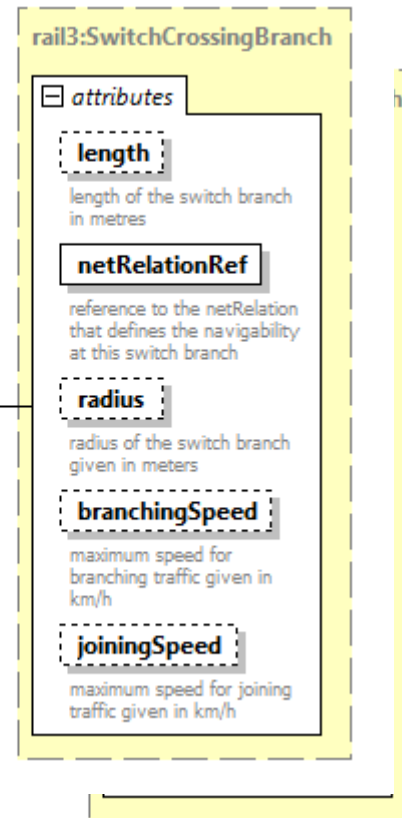

**rail3:straightBranch**  
2  
only for switch crossings: general track

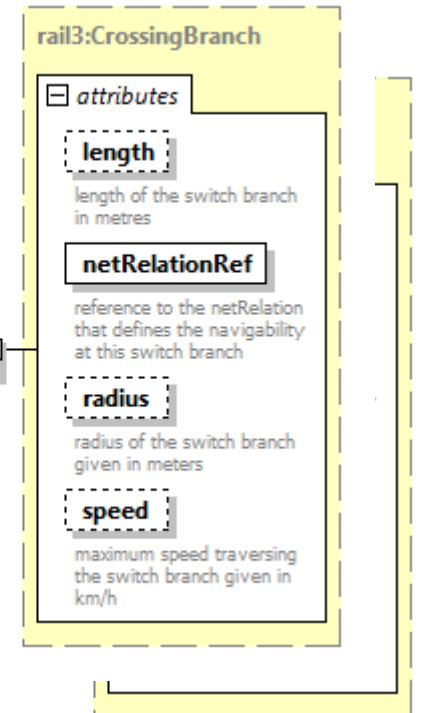

# Switch

- Weichen-Typ
  - Einfache Weiche
  - Innenbogenweiche
  - Außenbogenweiche
  - Einfache Kreuzungsweiche
  - Doppelte Kreuzungsweiche
  - Kreuzungsweichen-Teil

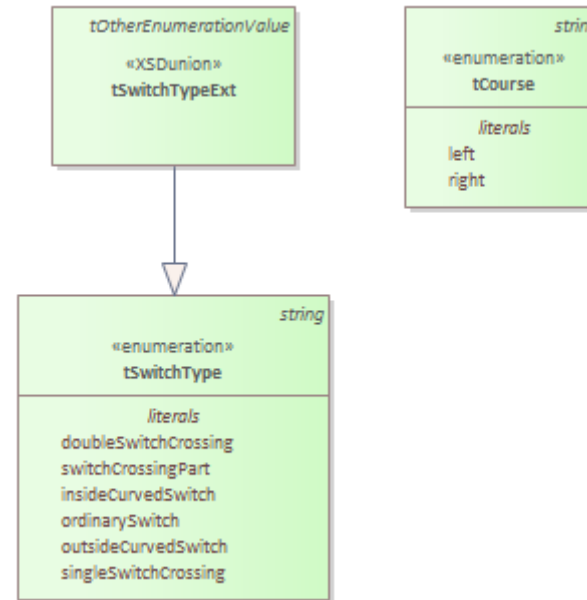

doubleSwitchCrossing	documentation	It is a point where two tracks cross each other and enable trains to move from one track to the other. It is used to guide a train from one straight track to another as well as going straight across. It allows going in eight directions.
switchCrossingPart	documentation	a switch being a part of a switch crossing
insideCurvedSwitch	documentation	has two curved branches directing in the same direction (either left or right) with one branch having a bigger radius than the other.
ordinarySwitch	documentation	a switch with a straight branch and a curved branch.
outsideCurvedSwitch	documentation	has two curved branches directing in different directions (left and right). The value of the radius may be similar with both branches.
singleSwitchCrossing	documentation	It is a point where two tracks cross each other and enable trains to move from one track to the other. It is combination of a simple crossing, switch and connecting tracks used to guide a train from one straight track to another as well as going straight across. It allows going in 6 directions.

# Switch

- Weichen-Herzstück

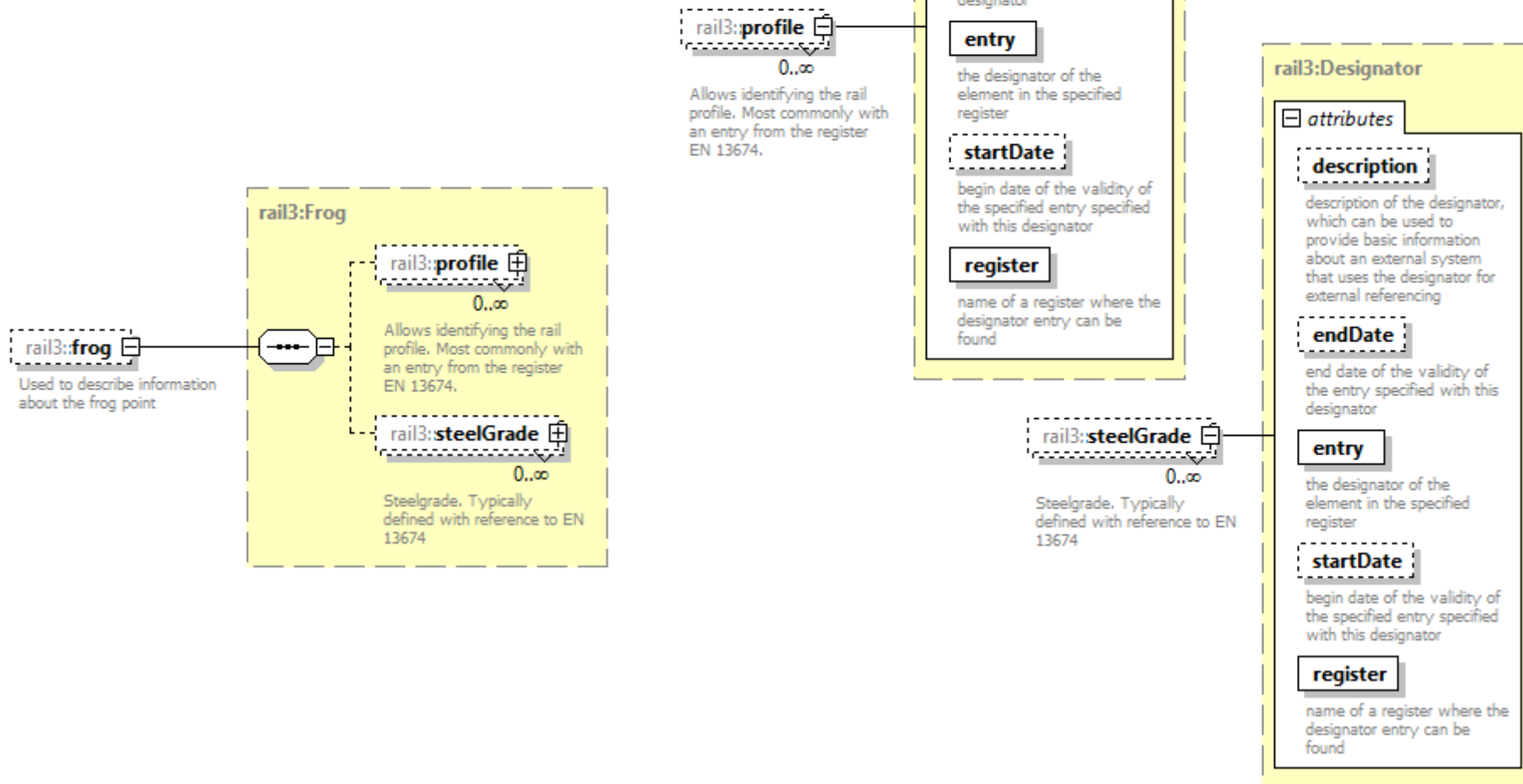

# Switch

- Radlenker

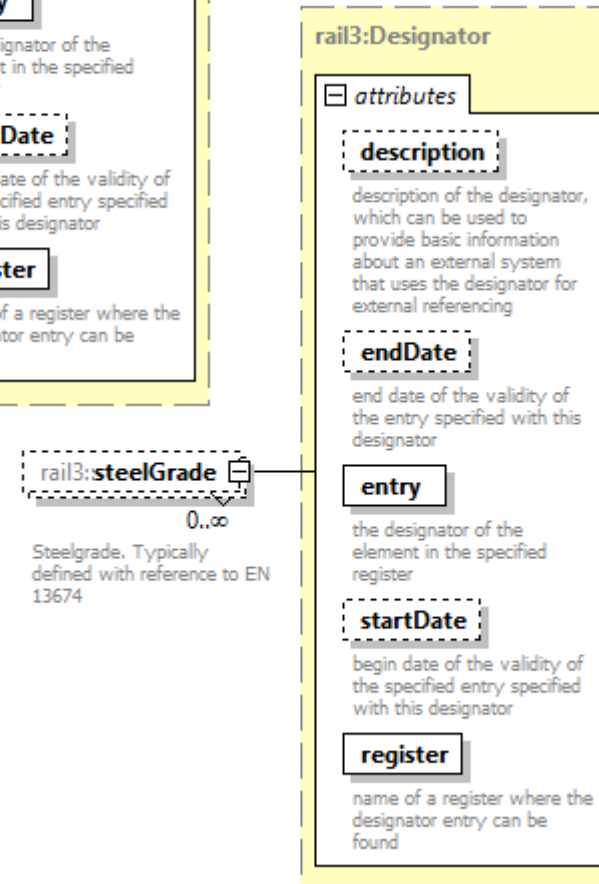
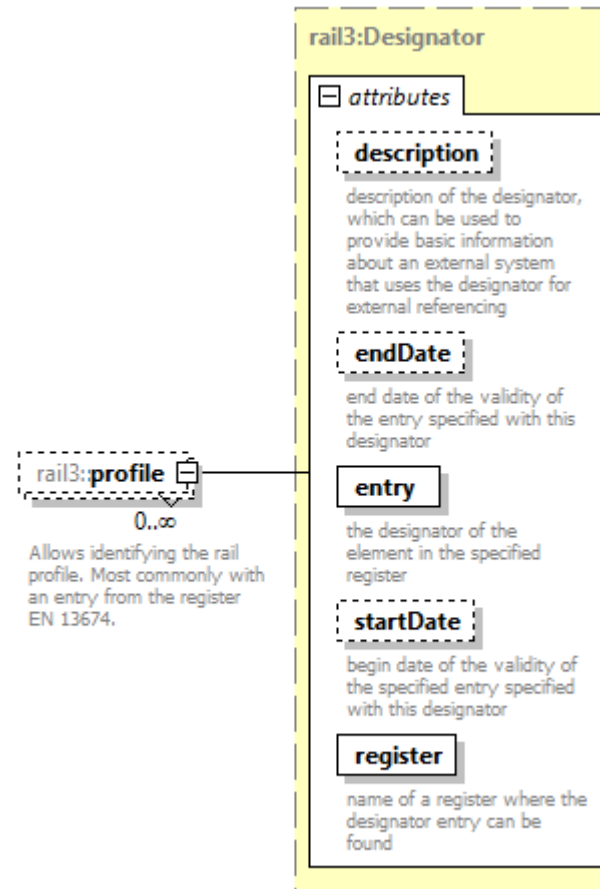
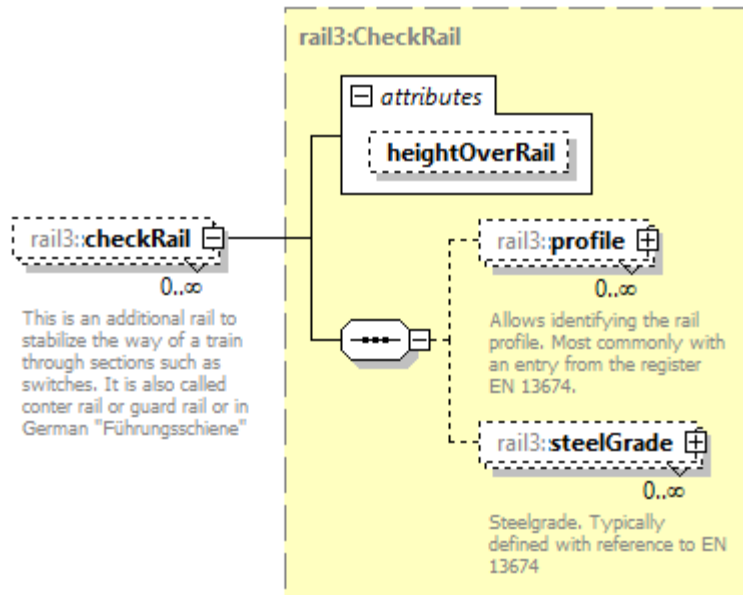

# Track Bed

- Track bed model (de: Gleiskörper-Oberbau)

## GLEISKÖRPER - QUERSCHNITT

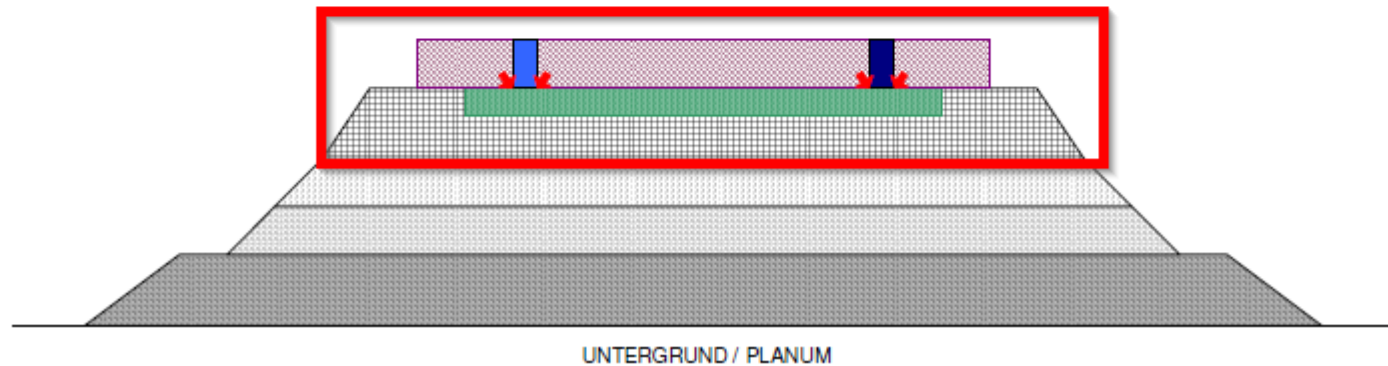
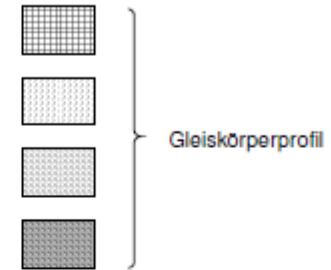
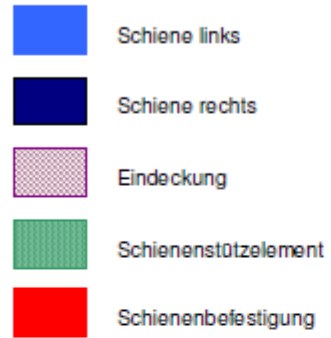

[https://de.wikipedia.org/wiki/Oberbau\\_\(Eisenbahn\)](https://de.wikipedia.org/wiki/Oberbau_(Eisenbahn))

# Track Bed

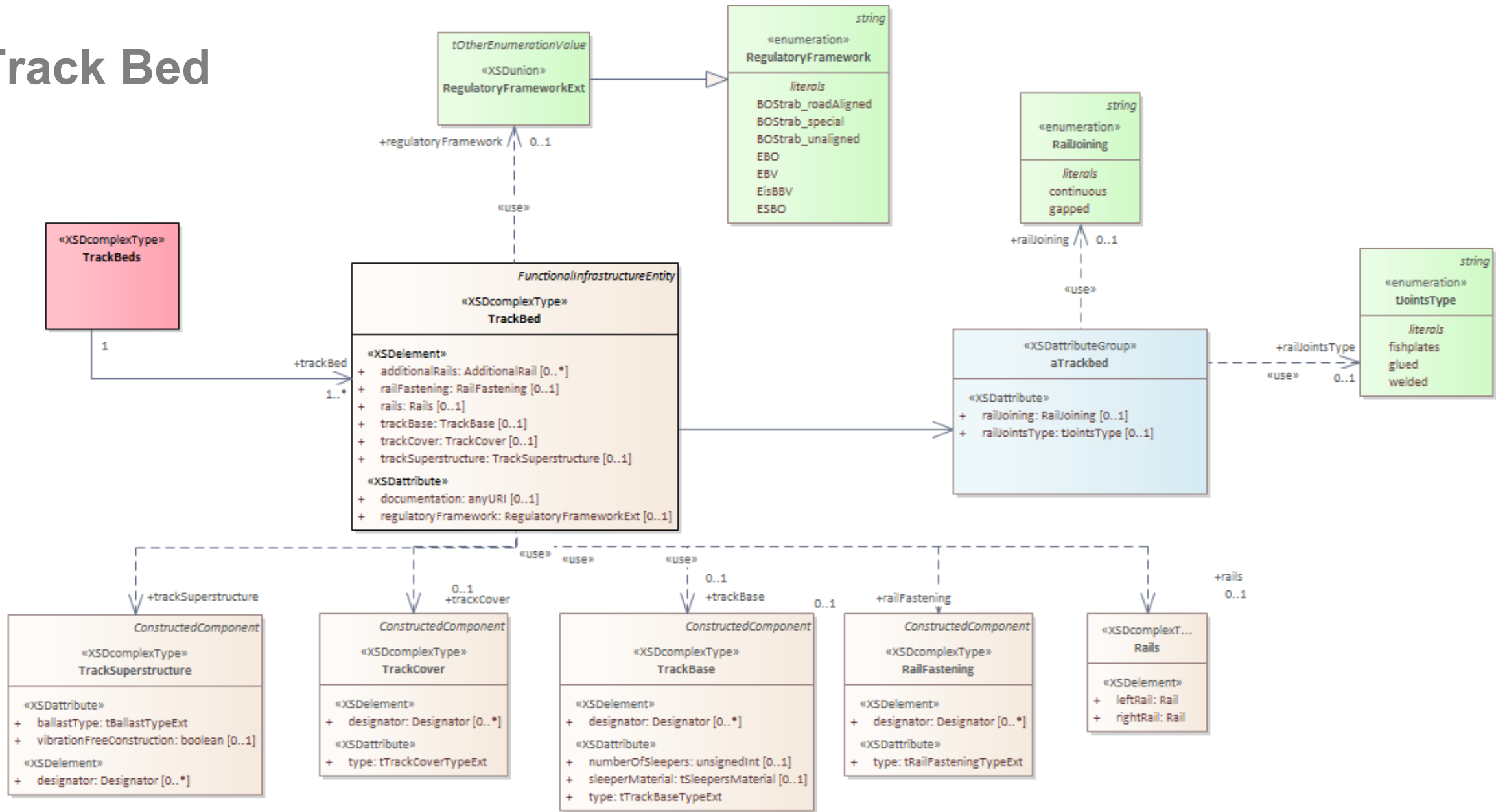

# Track Bed

- Track base (de: Schienenunterstützung)

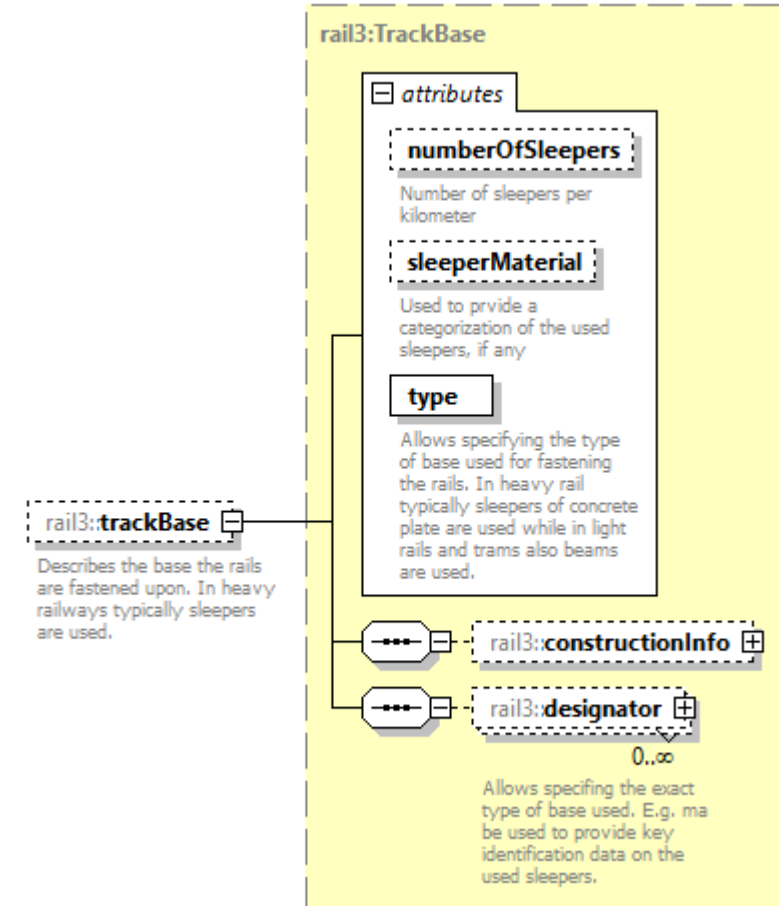
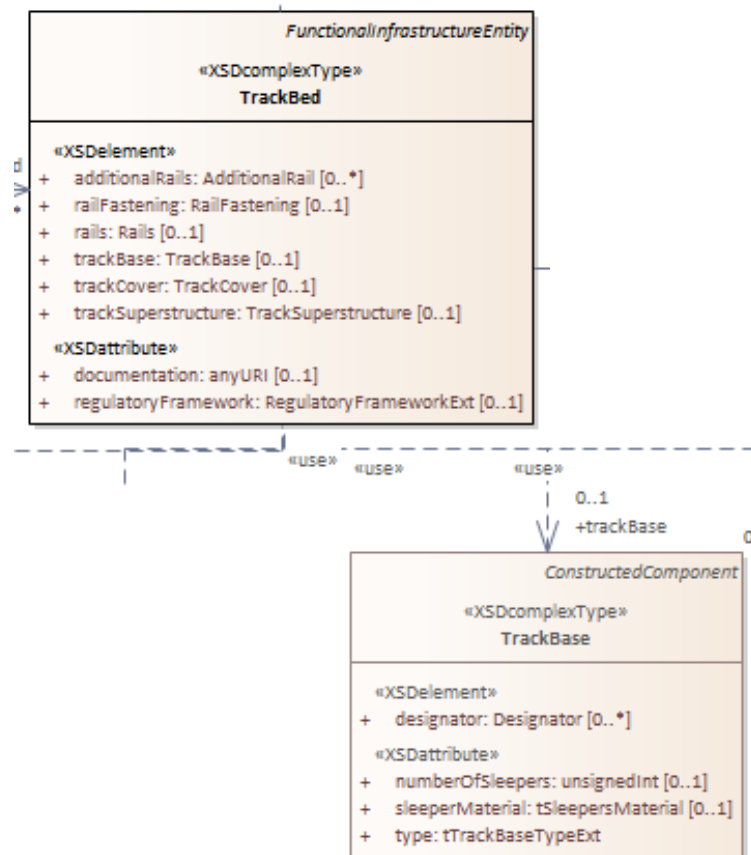

# Track Bed

- Track base (de: Schienenunterstützung)

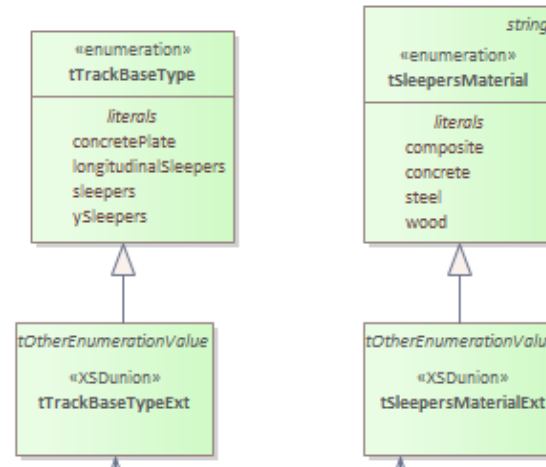

composite	documentation	the sleepers are made from a composite material.
concrete	documentation	the sleepers are made from concrete
steel	documentation	The sleepers are made from steel
wood	documentation	The sleepers are made from wood

concretePlate	documentation	The rails are attached to a concrete plate. This is typically the case for high speed railways.
longitudinalSleepers	documentation	The rails are attached to beams that are placed along the direction of the rail. This is a type of construction that is often used in light rails and trams.
sleepers	documentation	The rails are attached to sleepers that are placed crosswise (perpendicular) to the rails
ySleepers		

- Rail fastening (de: Schienenbefestigungsmittel)

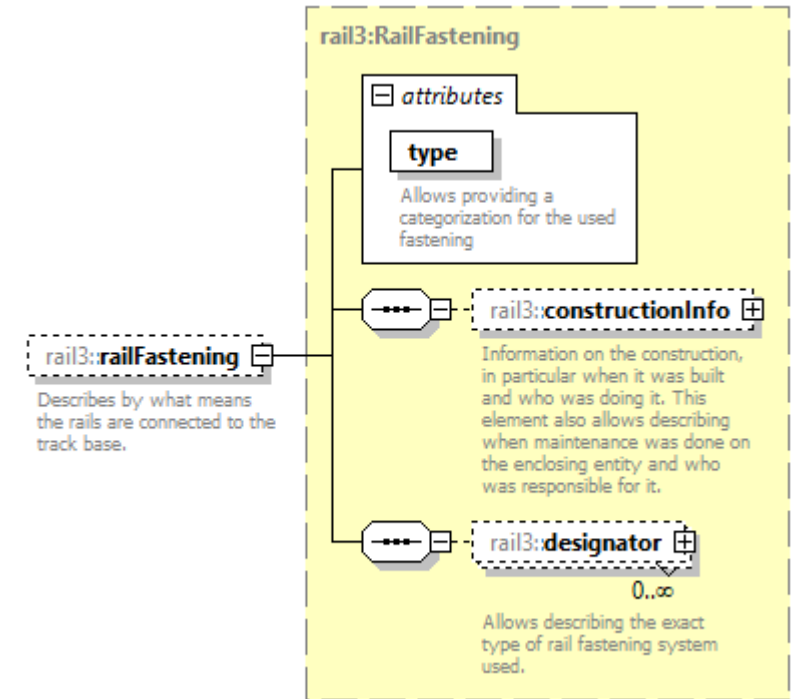
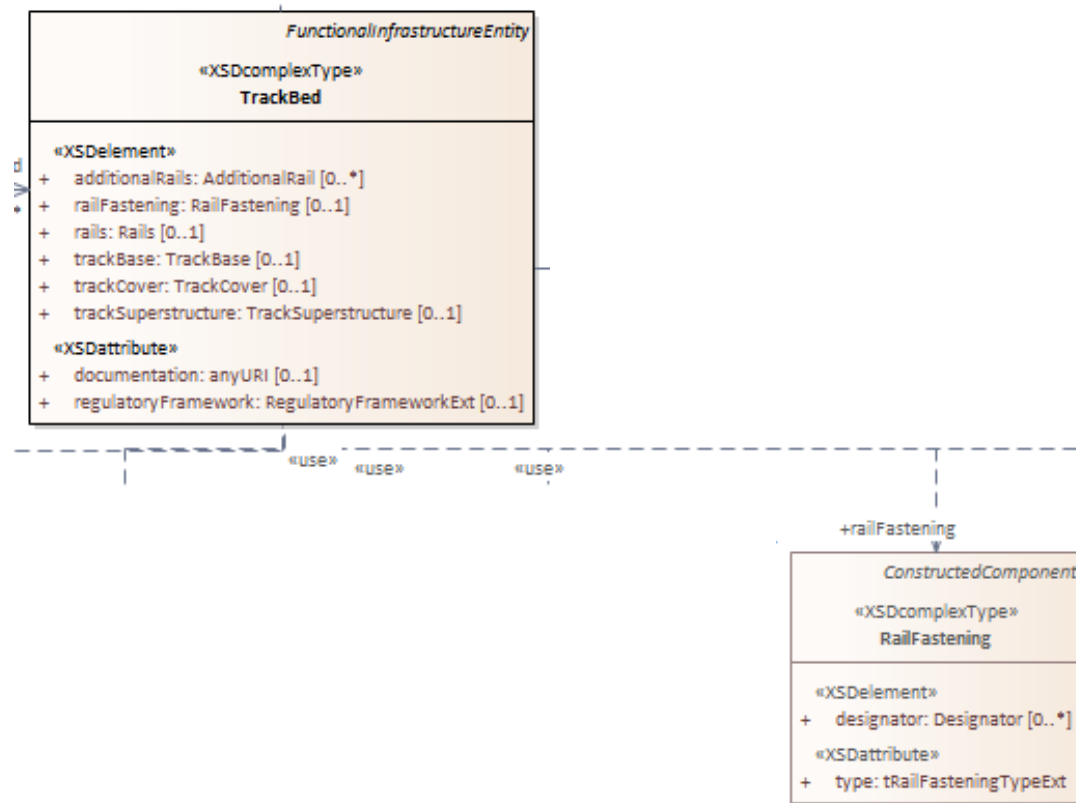

- Rail fastening (de: Schienenbefestigungsmittel)

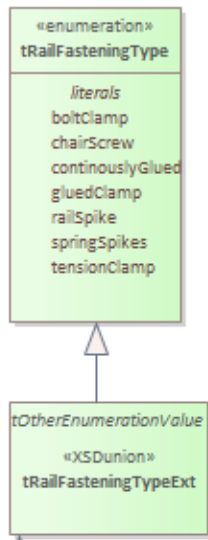

<b>boltClamp</b>	documentation a bolt is used to fix the rail to the base
<b>chairScrew</b>	documentation A chair screw (also known as coach screw [16]) is a large (~6 in or 152 mm length, slightly under 1 in or 25 mm diameter) metal screw used to fasten a rail. (DE: Schienenschraube)
<b>continuouslyGlued</b>	documentation The track is continuously glued to the base. This is a type of fastening often used in light rail or tramways.
<b>gluedClamp</b>	documentation used in light rail and tramways
<b>railSpike</b>	documentation A rail spike (also known as a cut spike or crampon) is a large nail with an offset head that is used to secure rails (DE: Schienennagel)
<b>springSpikes</b>	documentation Spring spikes or elastic rail spikes are used with flat-bottomed rail, baseplates and wooden sleepers. The spring spike holds the rail down and prevents tipping and also secures the baseplate to the sleeper. (DE: Doppelspannnagel)
<b>tensionClamp</b>	documentation The foot of the rail is fastened to the track base using a tension clamp that is bolted to the base. (DE: Oberbau W/Oberbau KS)

- Rail joints (de: Schienenverbindungsmittel)

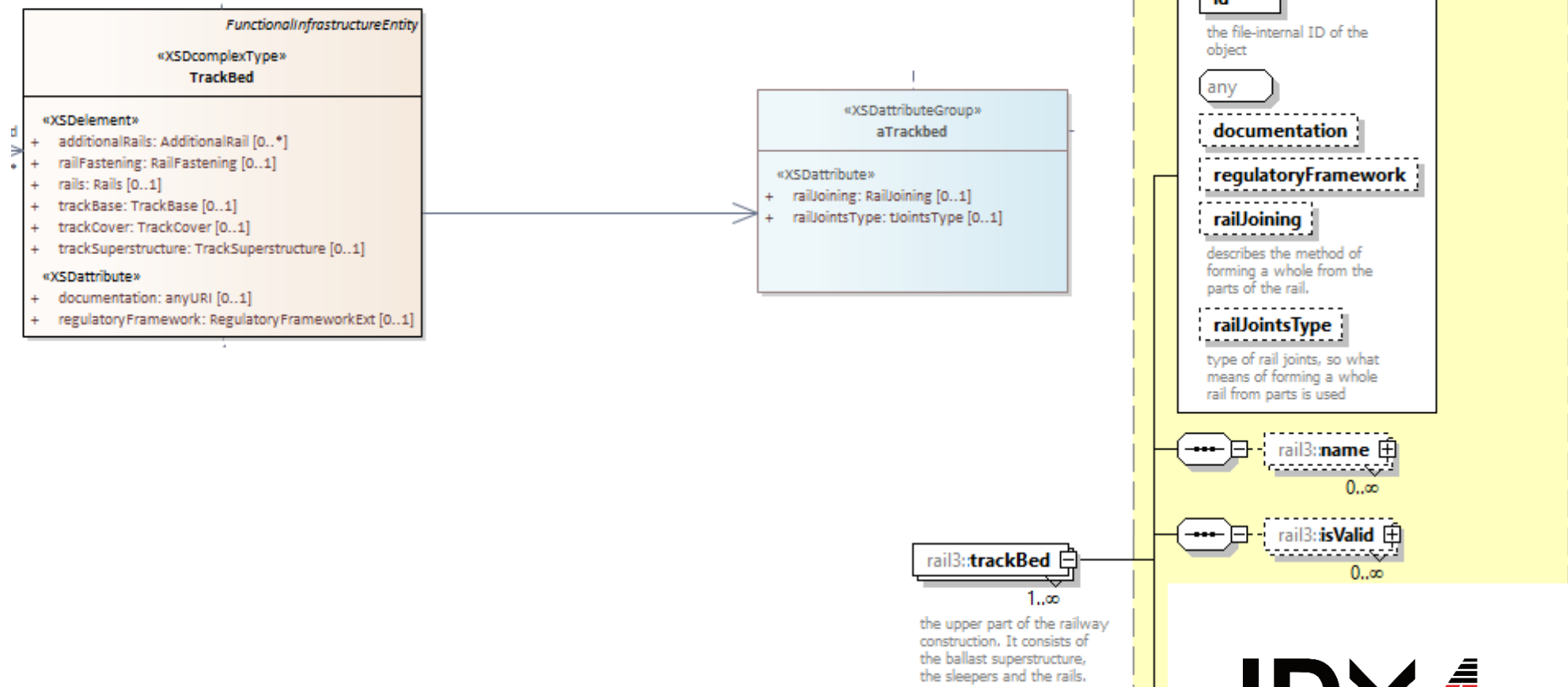

- Rail joints (de: Schienenverbindungsmitel)

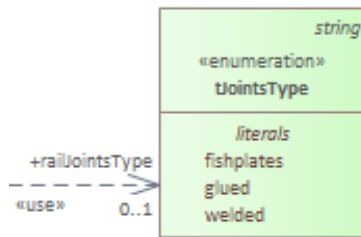

`fishplates` documentation

a metal connecting plate used to bolt the ends of two rails

`glued` documentation

Indicates that the individual rails are glued together. All the gaps are filled with epoxy resin, increases the strength

`welded` documentation

Indicates that the individual rails are welded together

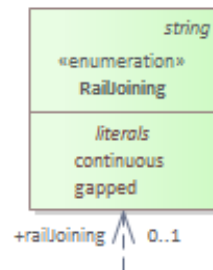

`continuous` documentation

continuous welded rail (CWR), sometimes referred to as ribbon rails or seamless rails. In this form of track, the rails are welded together by utilising flash butt welding to form one continuous rail that may be several kilometres long. Because there are few joints, this form of track is very strong, gives a smooth ride, and needs less maintenance; trains can travel on it at higher speeds and with less friction

`gapped` documentation

track is made using lengths of rail, bolted together using perforated steel plates known as fishplates. Small gaps which function as expansion joints are deliberately left between the rail ends to allow for expansion of the rails in hot weather. Because of these small gaps, when trains pass over jointed tracks they make a "clickety-clack" sound.

- Rails (de: Schienen)

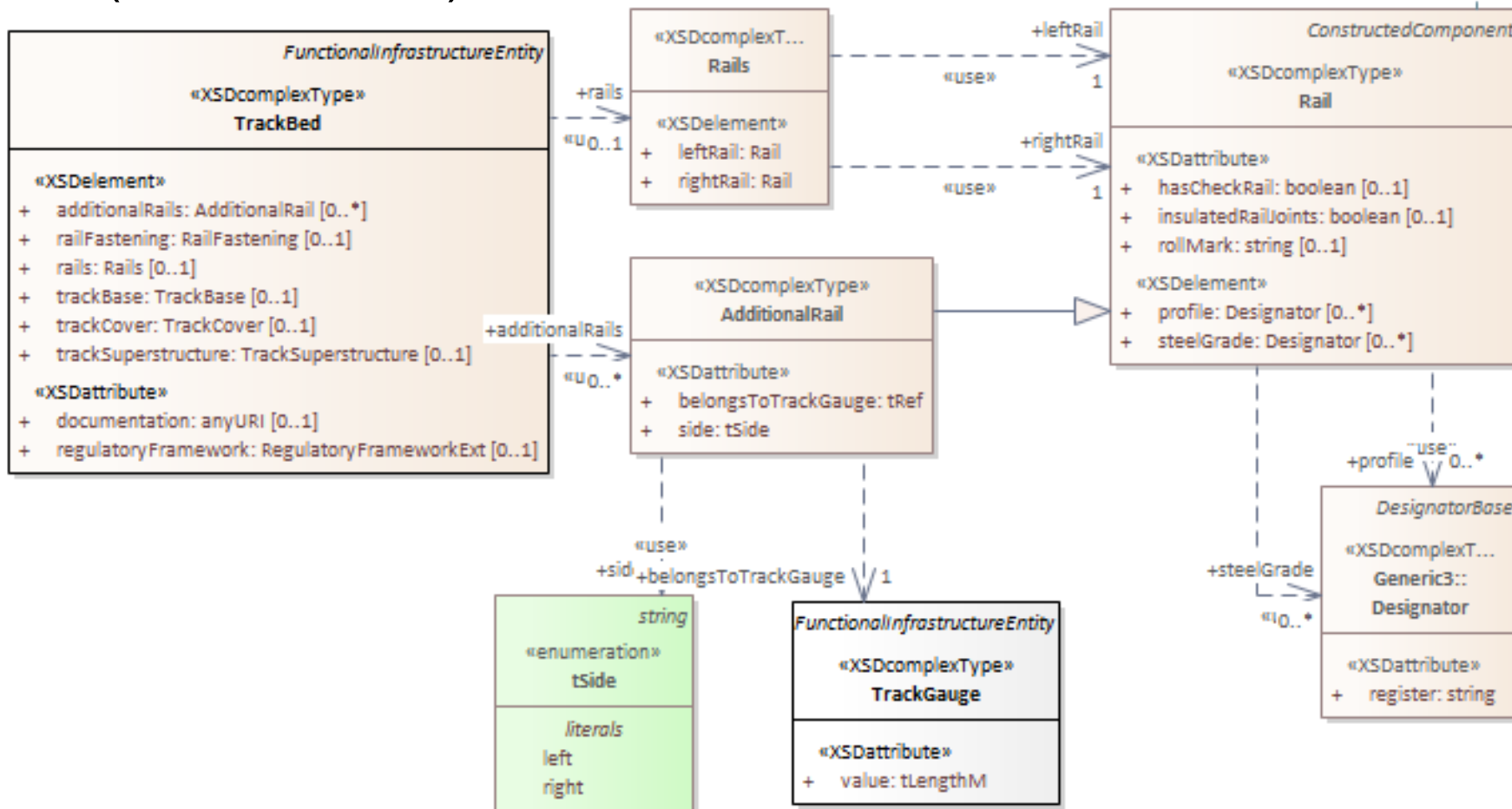

# Track Bed

- Rails (de: Schienen)

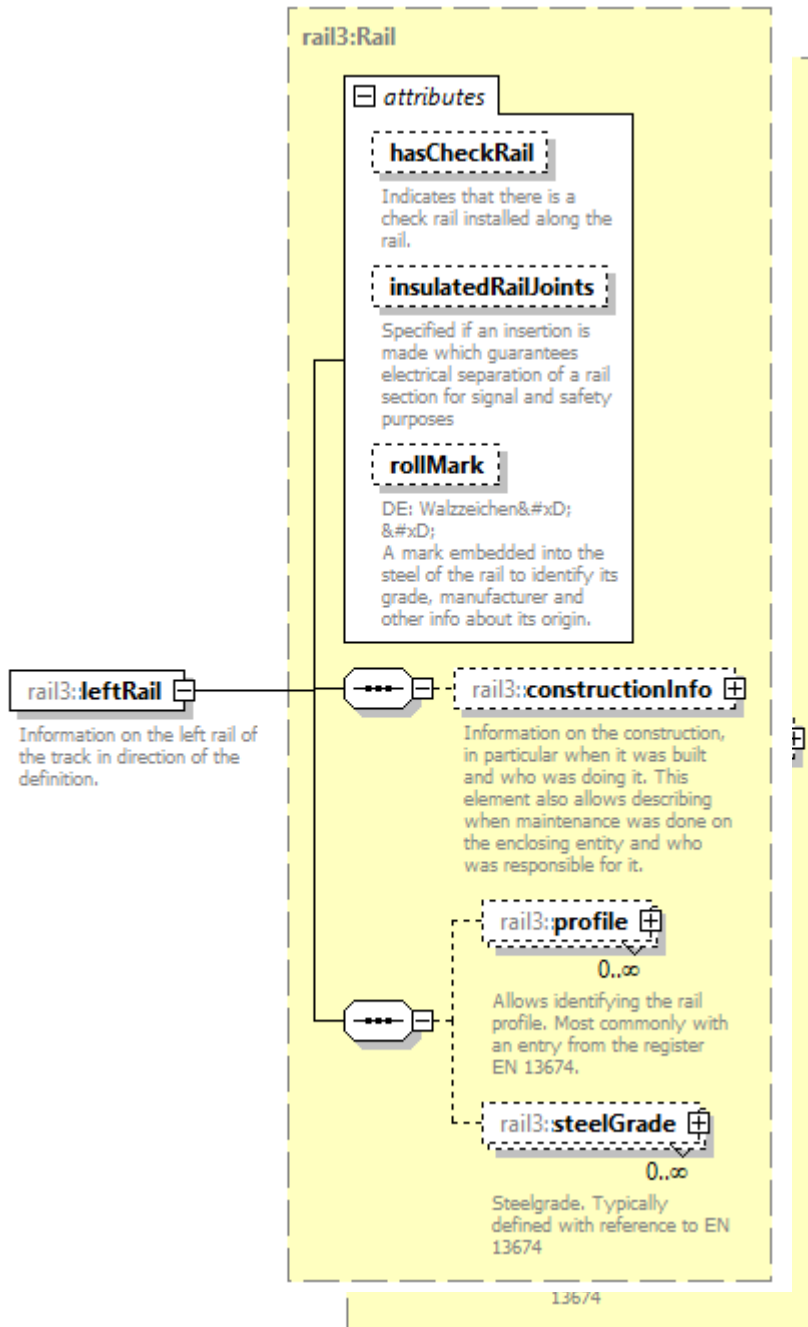
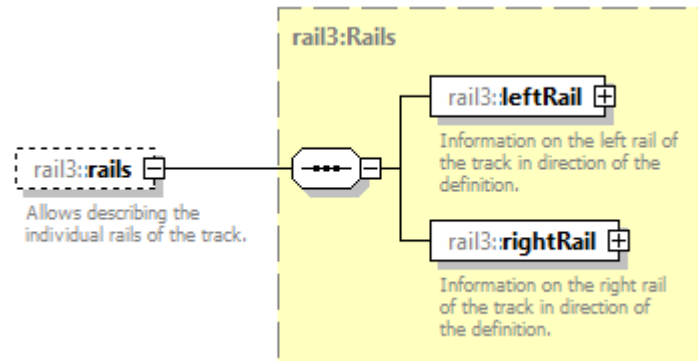

- Rails (de: Schienen)

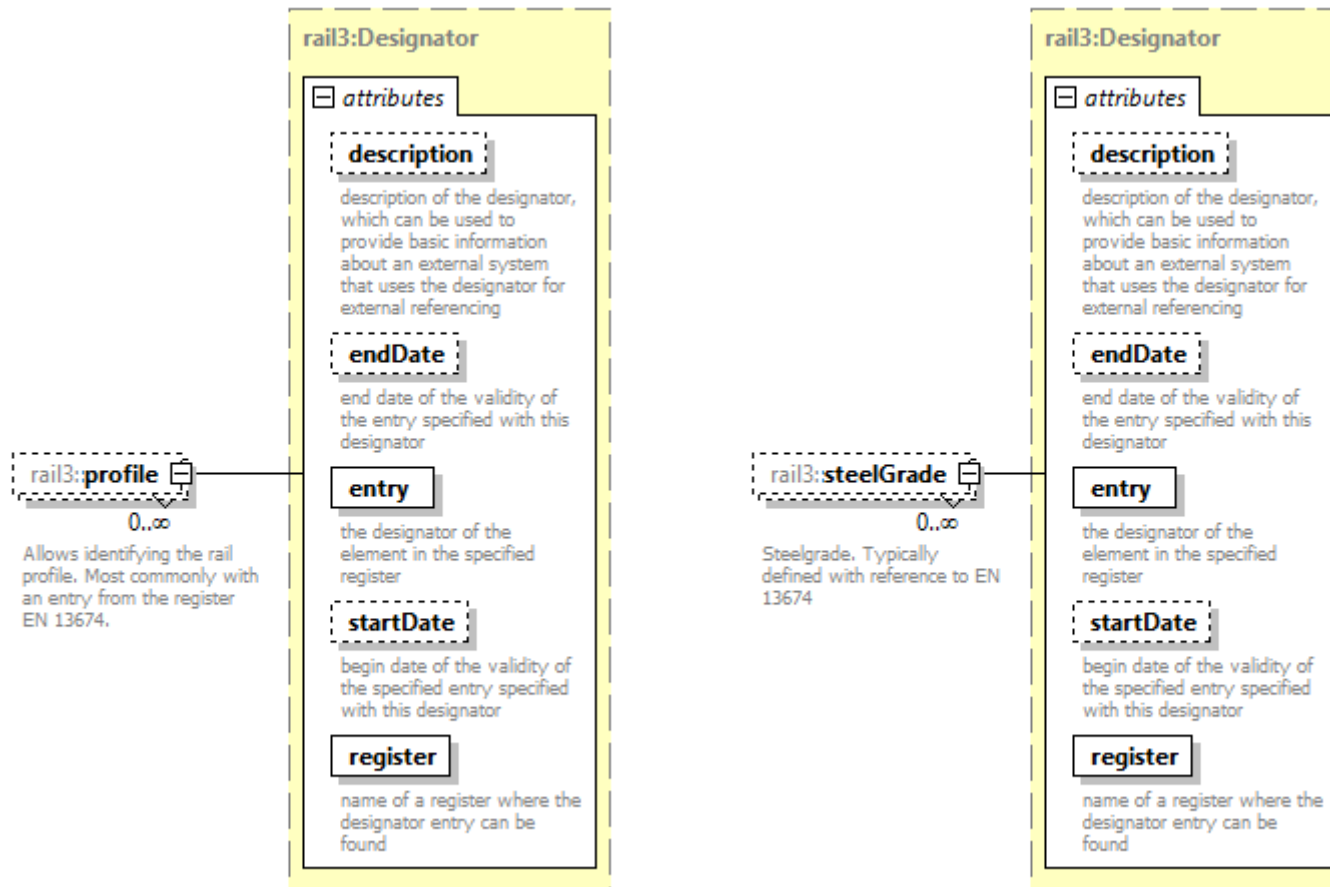

# Track Bed

- Rails (de: Schienen)

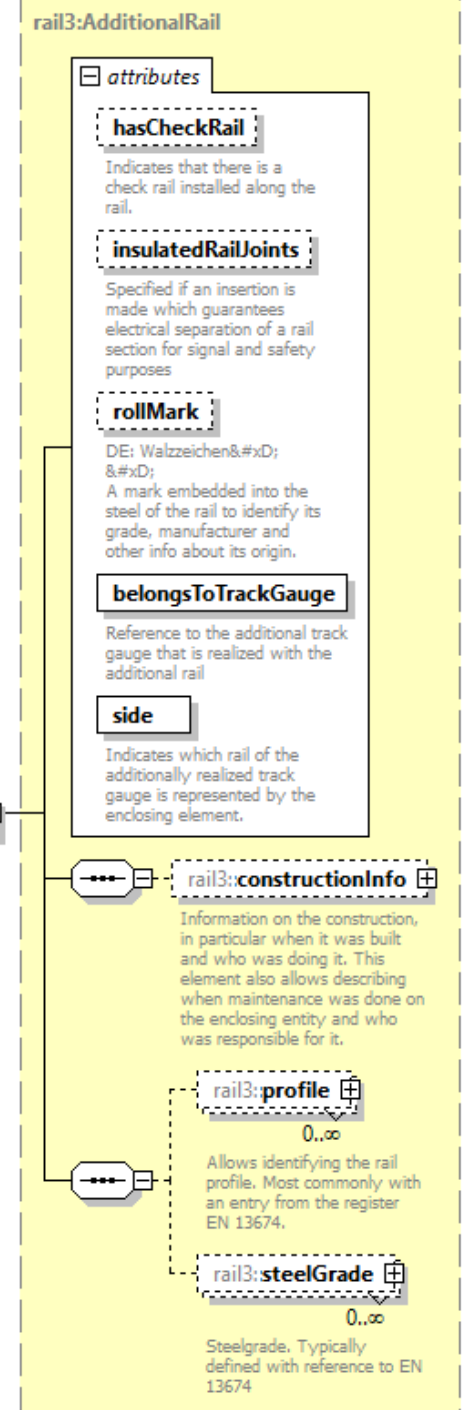
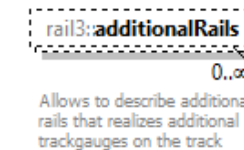
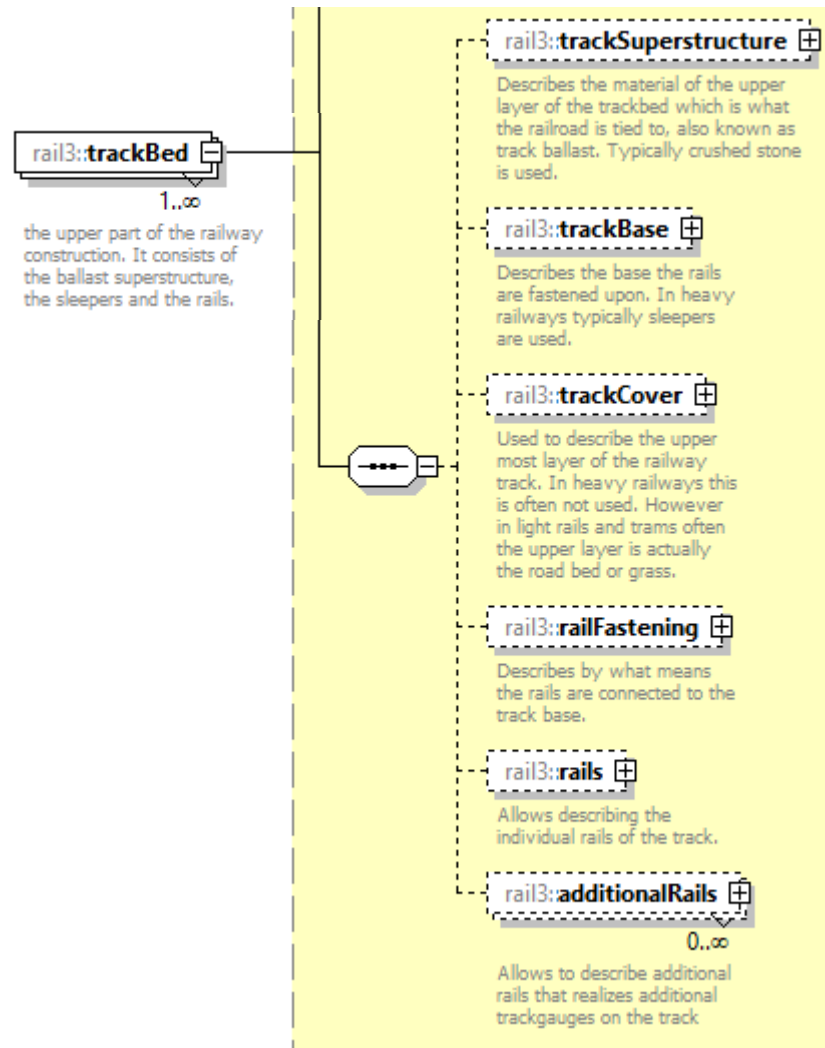

# Track Bed

- Track ballast & track cover (de: Gleisbettung)

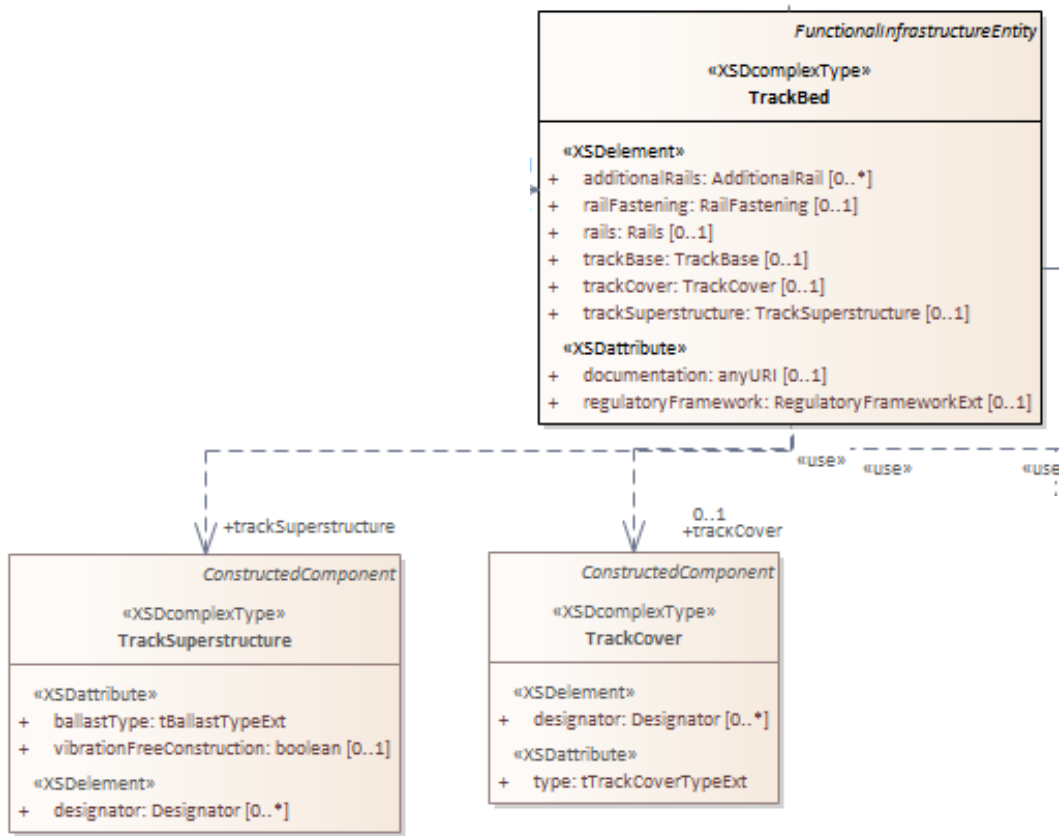

**rail3:trackSuperstructure**

Describes the material of the upper layer of the trackbed which is what the railroad is tied to, also known as track ballast. Typically crushed stone

**rail3:TrackCover**

**attributes**

- type**: Allows categorizing the track cover
- rail3:constructionInfo**: Information on the construction, in particular when it was built and who was doing it. This element also allows describing when maintenance was done on the enclosing entity and who was responsible for it.
- rail3:designator**: Allows providing detailed identification data for the used track cover

**rail3:trackCover**

Used to describe the upper most layer of the railway track. In heavy railways this is often not used. However in light rails and trams often the upper layer is actually the road bed or grass.

**rail3:TrackSuperstructure**

**attributes**

- ballastType**: allows categorizing the ballast material
- vibrationFreeConstruction**: Indicates that the used construction of the superstructure is built to absorb vibration from trains by usage of materials such as elastic mats installed below the ballast.
- rail3:constructionInfo**: Information on the construction, in particular when it was built and who was doing it. This element also allows describing when maintenance was done on the enclosing entity and who was responsible for it.
- rail3:designator**: Allows specifying the exact type of material used as track ballast.

- Track ballast & track cover (de: Gleisbettung)

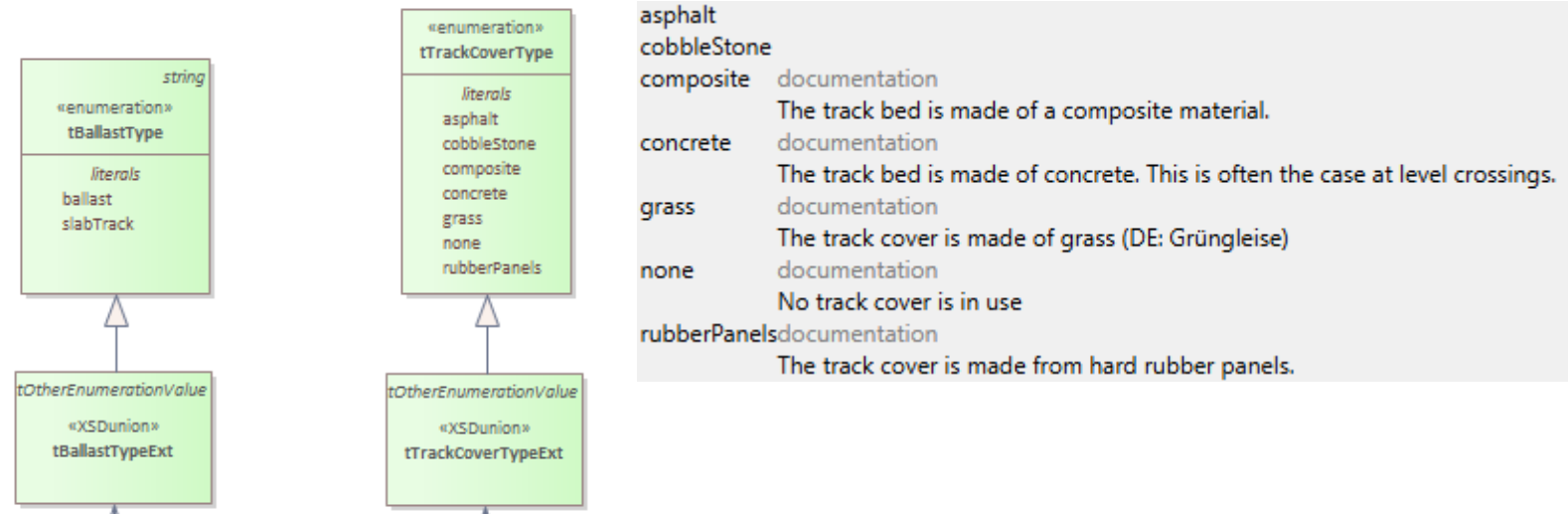

asphalt  
cobbleStone  
composite documentation  
The track bed is made of a composite material.  
concrete documentation  
The track bed is made of concrete. This is often the case at level crossings.  
grass documentation  
The track cover is made of grass (DE: Grüngleise)  
none documentation  
No track cover is in use  
rubberPanels documentation  
The track cover is made from hard rubber panels.

**ballast** documentation  
"Track ballast is the material which forms the trackbed upon which railroad ties (UK: sleepers) are laid. It is packed between, below, and around the ties. It is used to bear the compression load of the railroad ties, rails, and rolling stock; to facilitate drainage; and keep down vegetation that can compromise the integrity of the combined track structure. Ballast also physically holds the track in place as the trains roll over it. Not all types of railway tracks use ballast. [Wikipedia]"

**slabTrack** documentation  
A ballastless track or slab track is a type of railway track infrastructure in which the traditional elastic combination of sleepers and ballast is replaced by a rigid construction of concrete or asphalt [Wikipedia].

# Survey Data

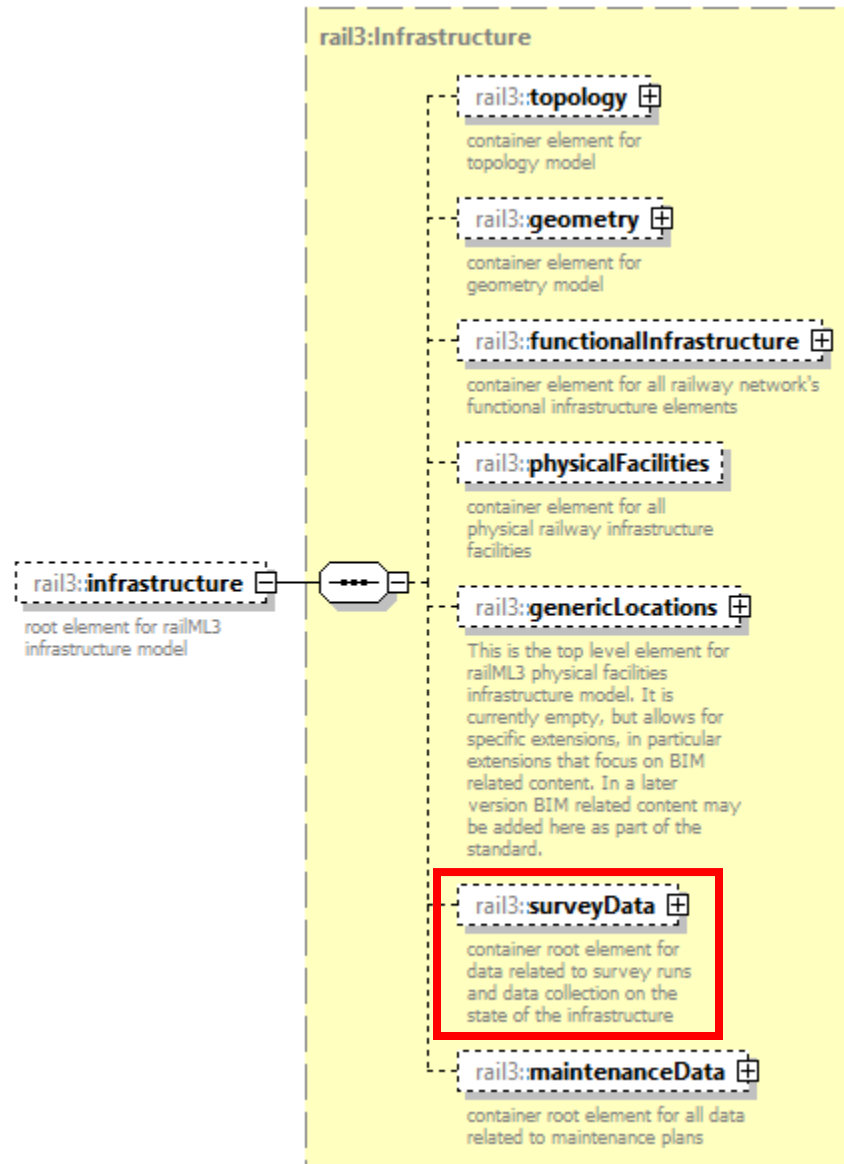

- Surveys bestehen aus
  - surveyRuns □ Messfahrten
  - surveyFindings □ gefundene Fehler
  - surveyResources □ Messdaten

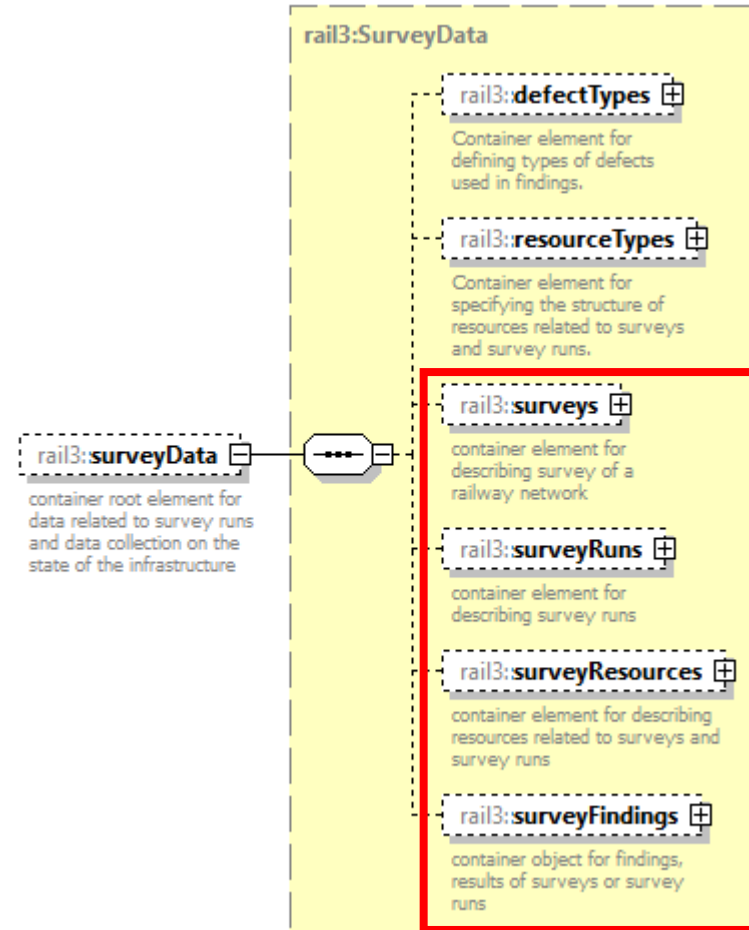

- **Survey** sammelt Meta-Daten
  - Designators (Bezeichner)
  - Verantwortliche Organisationseinheit
  - Zeitrahmen der Messfahrt
  - Projektbezug
  - Informationen zu beteiligtem Team

```
<organizationalUnits>
  <organizationalUnit id="org01">
    <name language="de" name="Erdmann Softwaregesellschaft mbH"/>
    <isContractor/>
  </organizationalUnit>
  <organizationalUnit id="org02">
    <name language="de" name="Straßenbahninfrastrukturverwaltung"/>
    <isInfrastructureManager/>
  </organizationalUnit>
</organizationalUnits>
<projects>
  <project id="pr01">
    <name language="de" name="Messzyklus 11/2025"/>
  </project>
</projects>
</common>
<infrastructure>
  <surveyData>
    <surveys>
      <survey projectRef="pr01" team="Erdmann Projekt Team">
        <responsibleOrganizationalUnitRef ref="org01"/>
        <responsibleOrganizationalUnitRef ref="org02"/>
        <timePeriod from="2025-11-10" to="2025-11-14"/>
      </survey>
    </surveys>
  </surveyData>
</infrastructure>
```

# Survey Data

## ■ Survey Run

- beschreibt wie die Daten aufgenommen wurden
- Ortsbezug: Von wo bis wo wurde eine Messfahrt aufgenommen
- Verweist auf die Ressourcen und die gefundenen Fehler

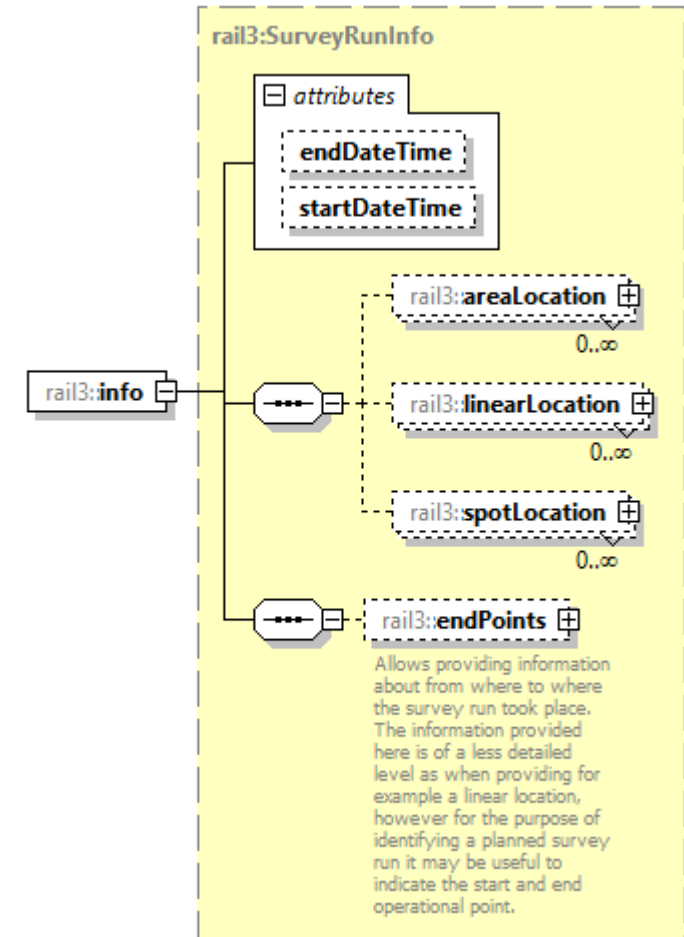
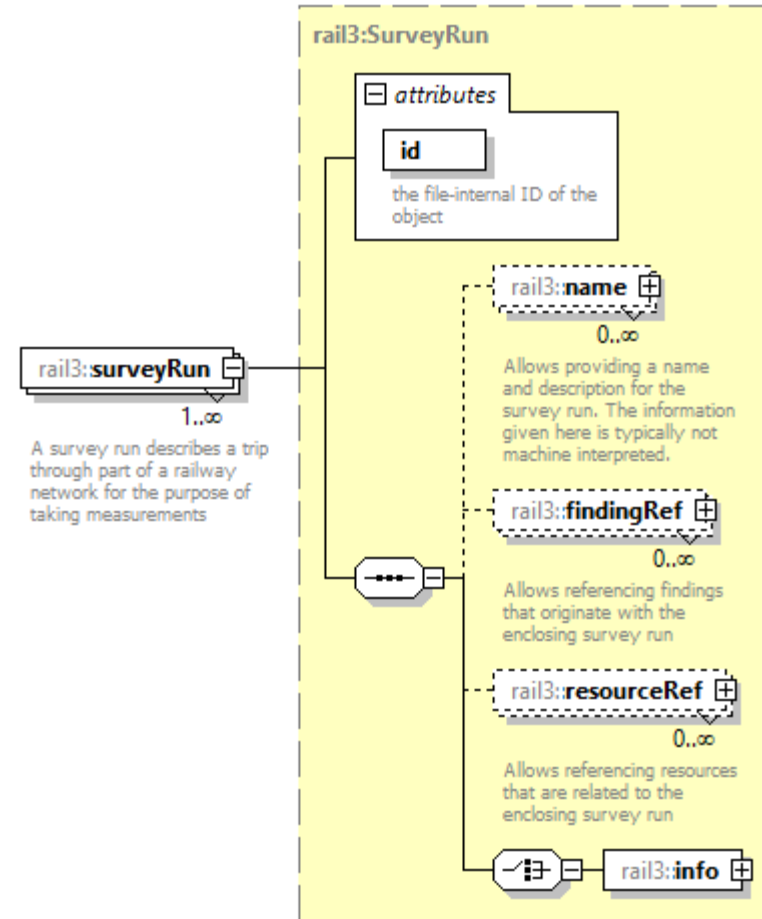

# Survey Data

## ■ Survey Resources

- Messdaten...
- Beschreibt Ort und Zeit der Datenaufnahme
- Ort kann in Sektionen unterteilt werden (unterstützt Segmentierung Tabellen-basierter Daten)

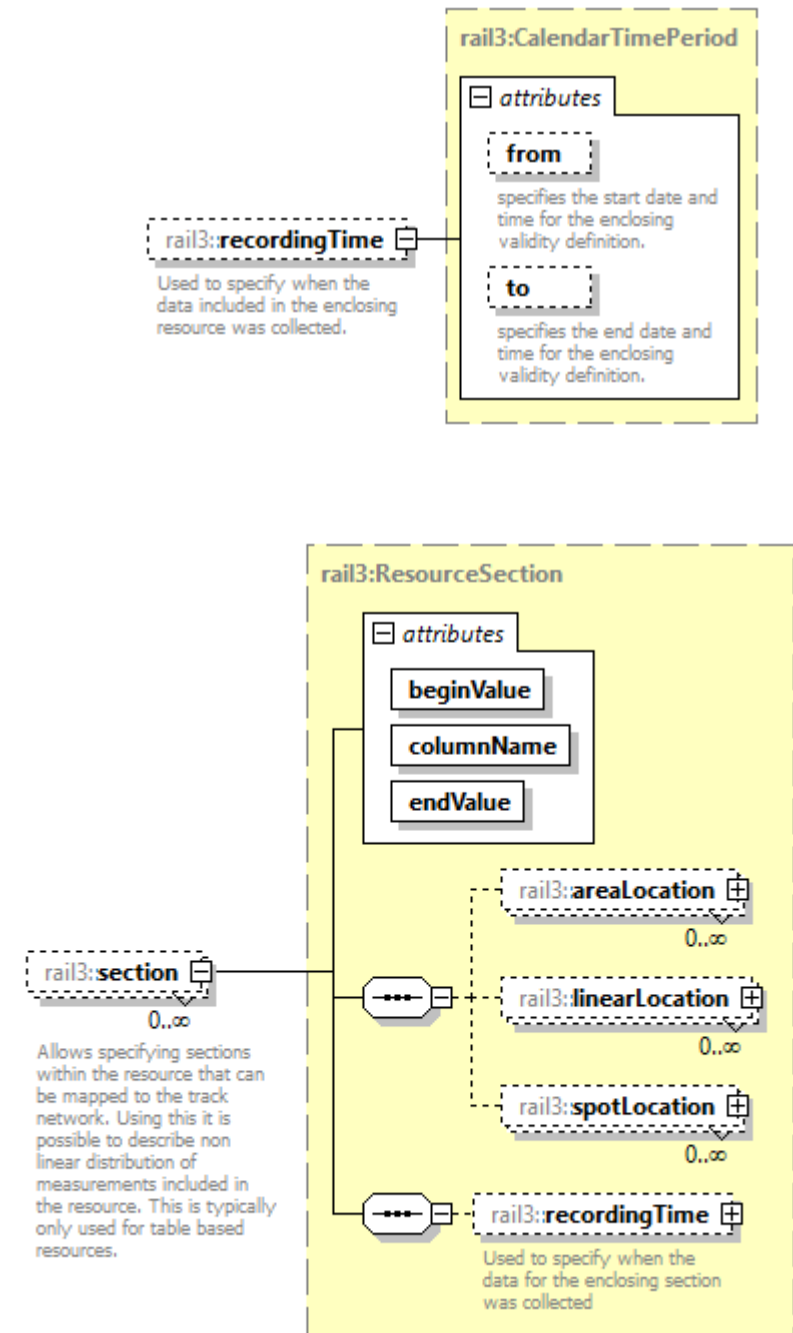
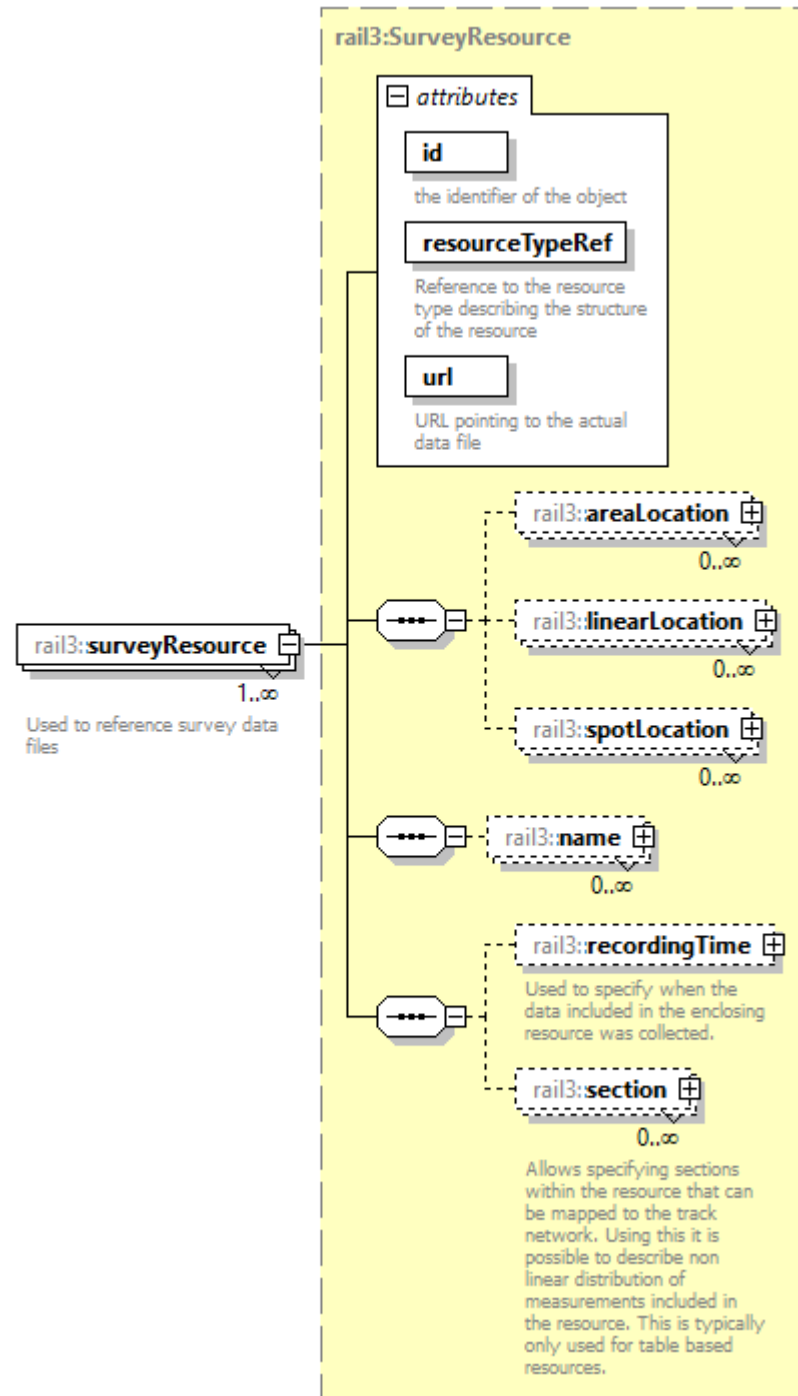

# Survey Data

## Survey Resources

- Referenzierung externer Datenbestände via @resourceTypeRef

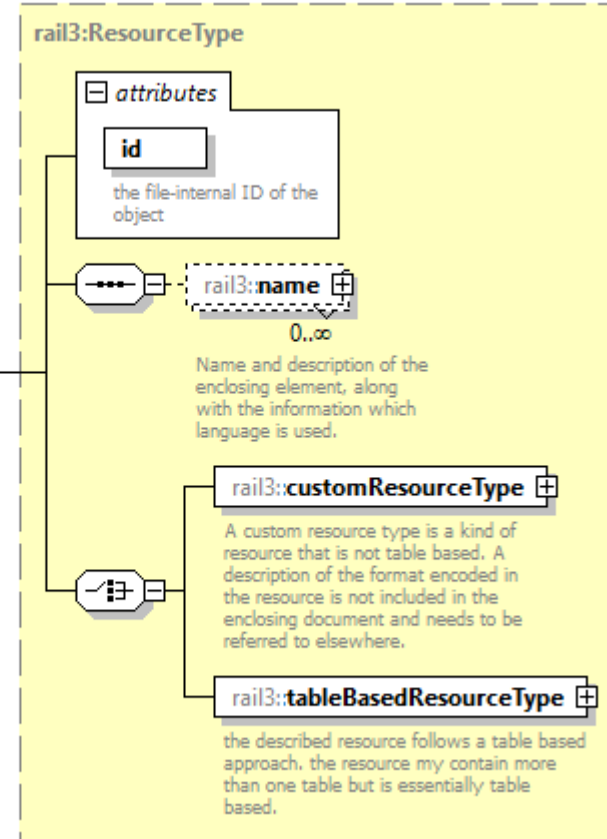
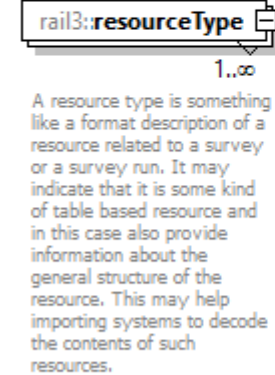
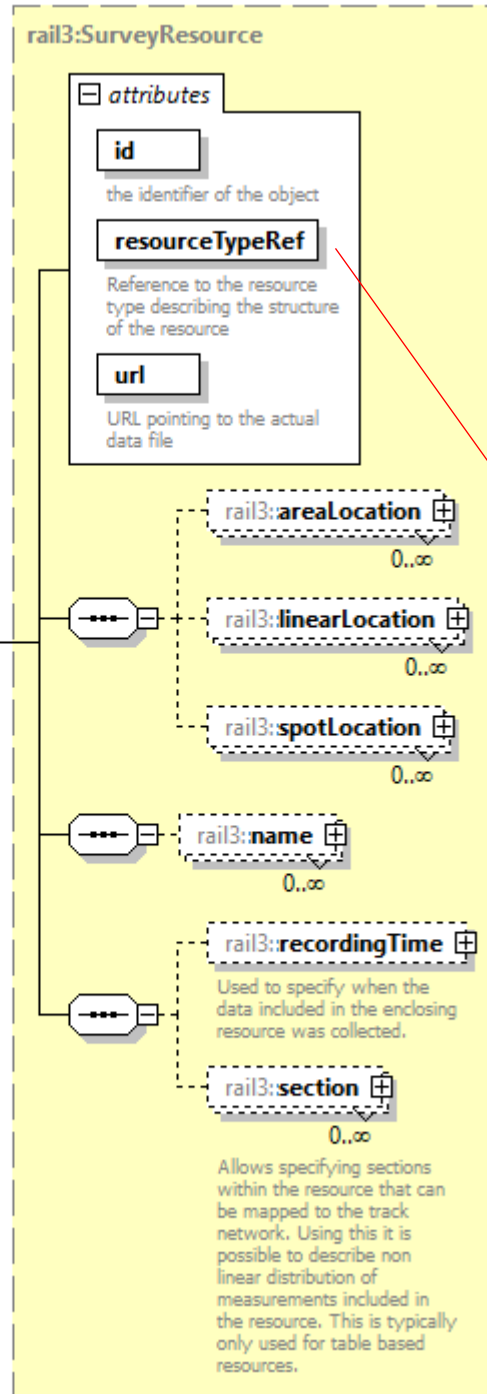
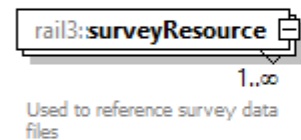
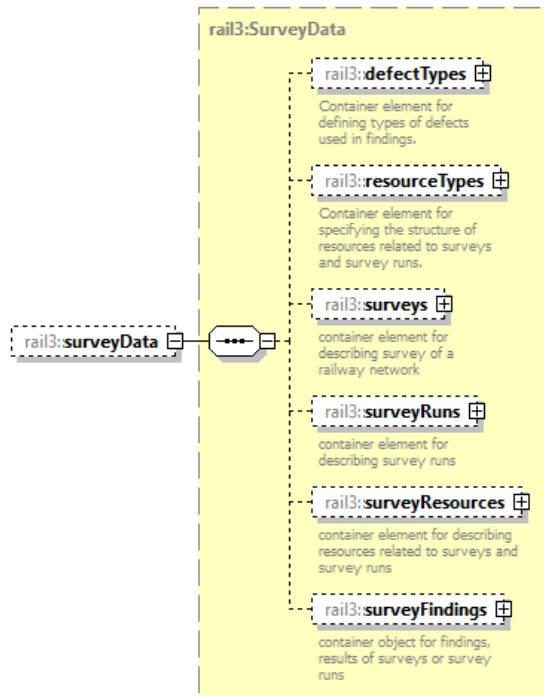

## Survey Resources

- Unterstützung für
  - Binary
    - DICONDE
    - proprietary

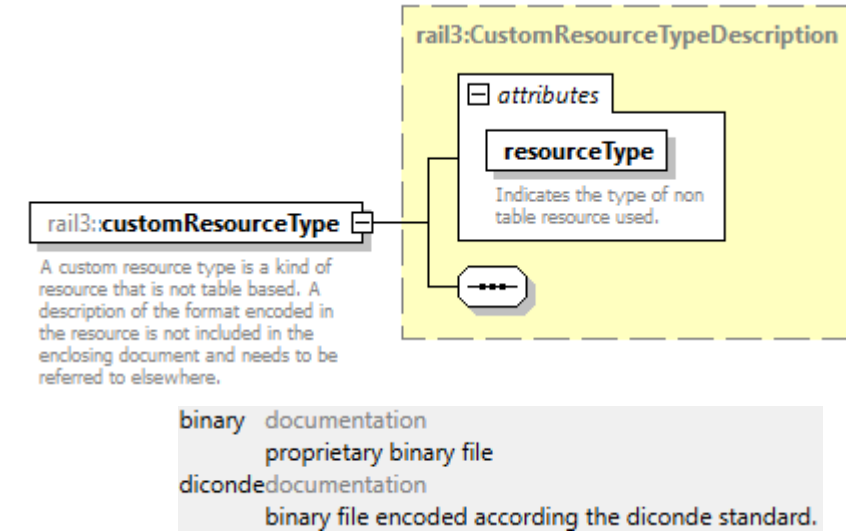
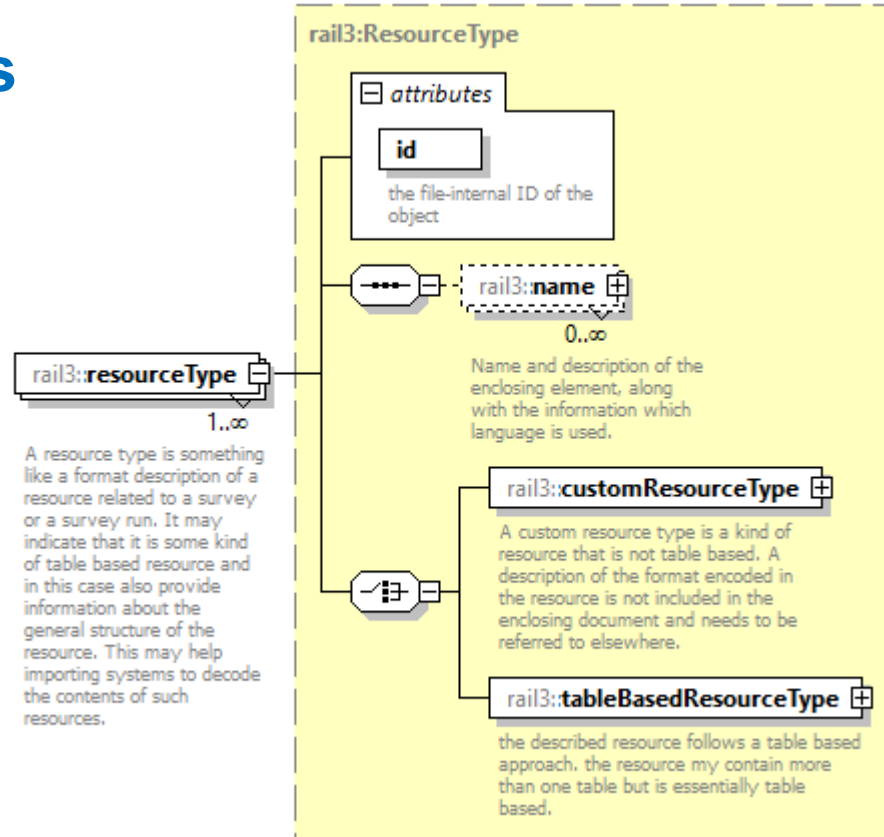

# Survey Data

## Survey Resources

- Unterstützung für
  - Table based

boolean	documentation Values are limited to "true" and "false"
dateTime	documentation A datetime value encoded according to ISO 8601, e.g. 2025-09-03T06:28:10Z or 2025-09-02T18:28:10-12:00
duration	documentation a time encoded as xs:duration, e.g. PT3M2S
floatingpoint	documentation A floating point number with a decimal point expressed as dot
integer	documentation an integer value with no separators, e.g. 1000000
string	documentation a string value

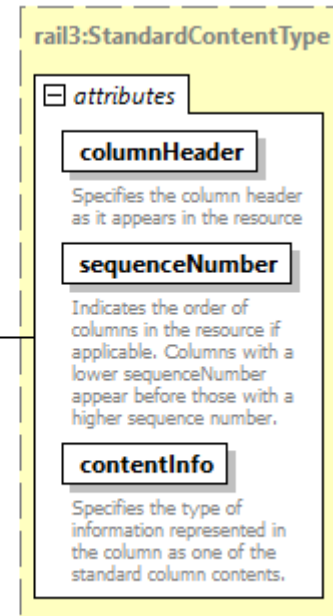
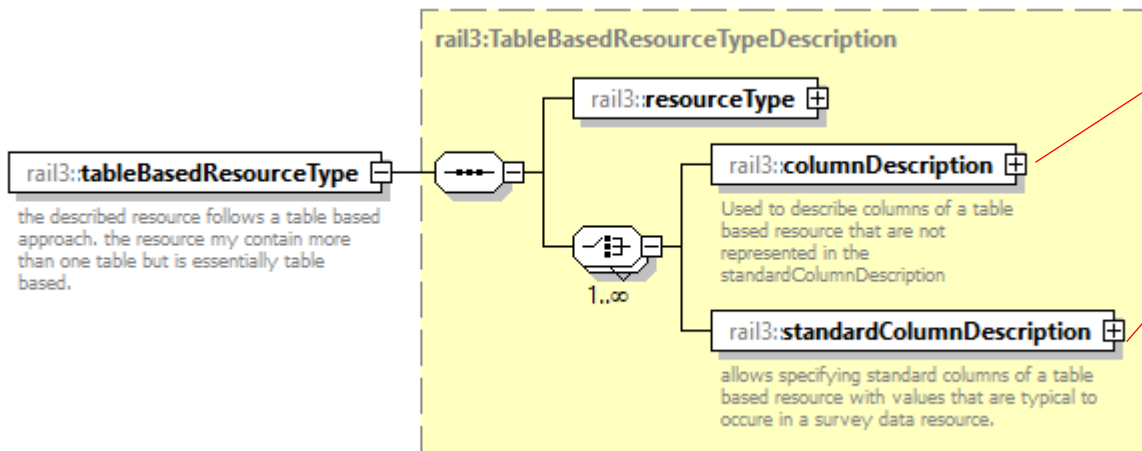
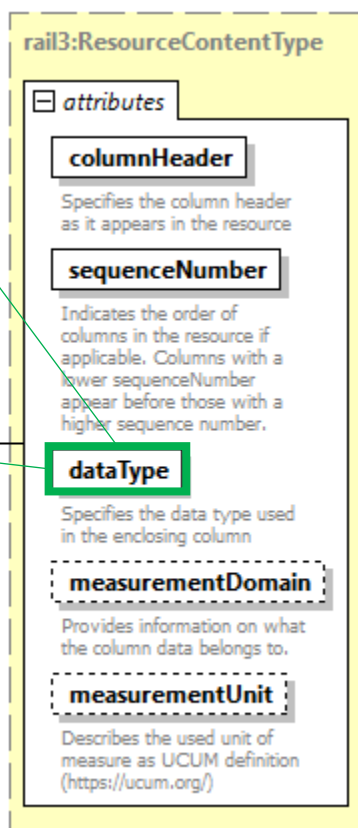
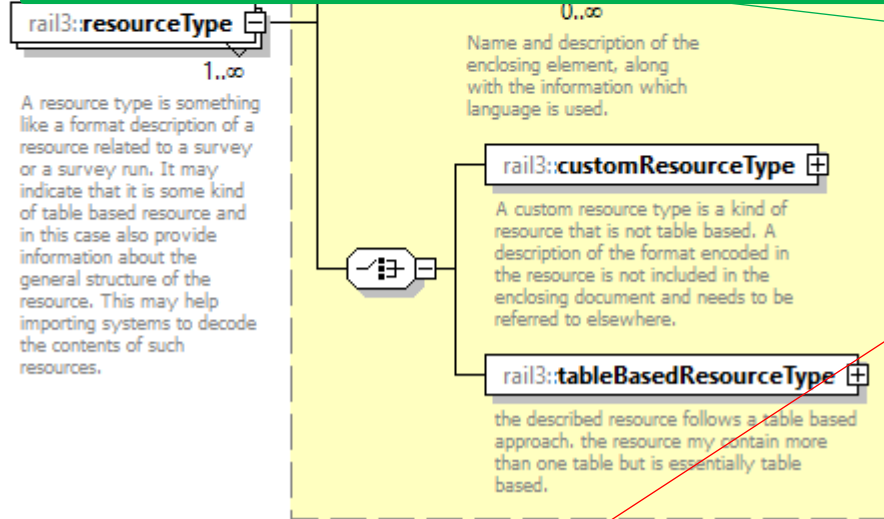

**rail3:standardColumnDescription** (1..∞)  
allows specifying standard columns of a table based resource with values that are typical to occur in a survey data resource.

## Survey Resources

- Unterstützung für
  - Table based
    - CSV
    - Excel
    - Parquet
    - SQLite

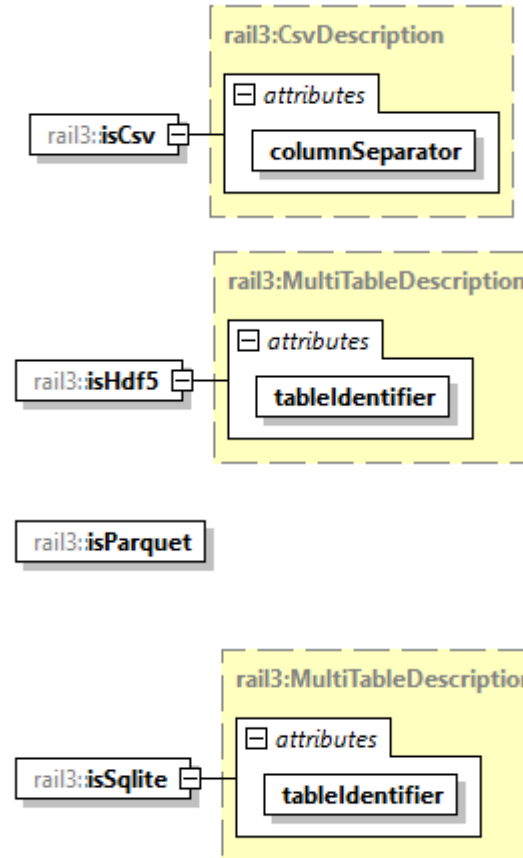
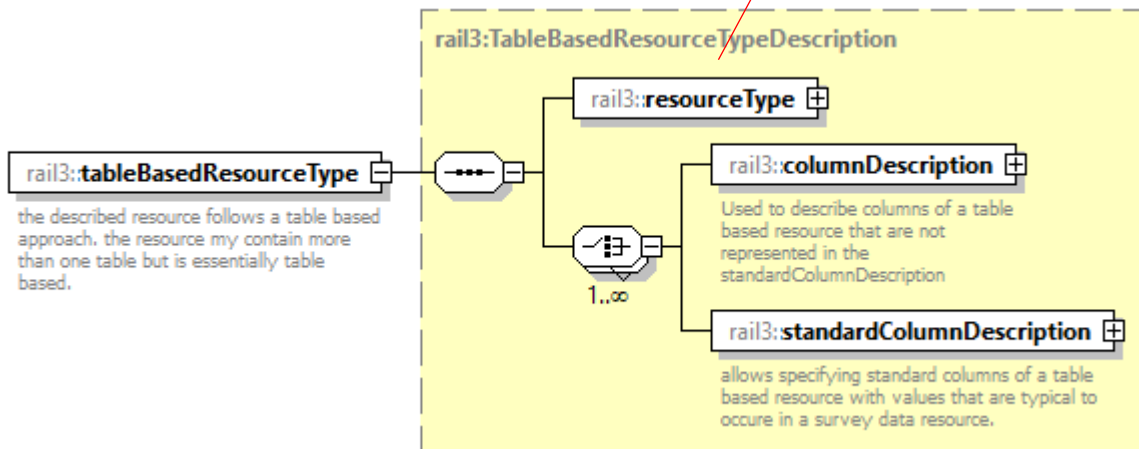
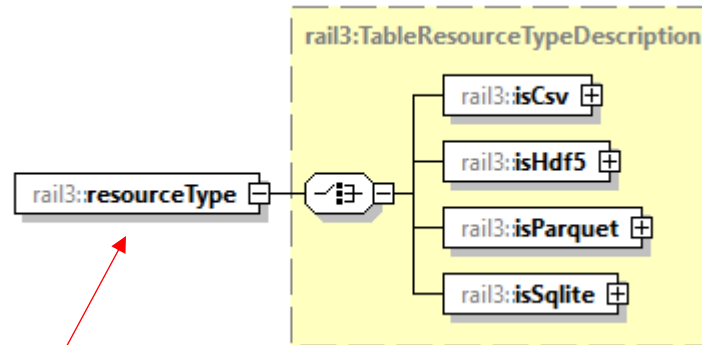

## ▪ Survey Resources

- Unterstützung für
  - Table based
    - CSV
    - Excel
    - Parquet
    - SQLite
  - Struktur tabellen-basierter Messdaten kann spezifiziert werden
    - Spalten können durch ihren Datentyp angegeben werden (string, integer, duration, ...)
    - Oder als vordefinierter Inhalt:
      - CurrentSpeed in Kmph
      - OffsetDistanceToStart
      - GPS lon, lat
      - ...

## Findings

- Zusammenfassung der Messfahrt-Ergebnisse
- Ort des Fehlers
- Modellierung erweiterbar
- Klassifikation von Fehlern basierend auf Standards
- Fehler-Schwere (severity) can angegeben werden

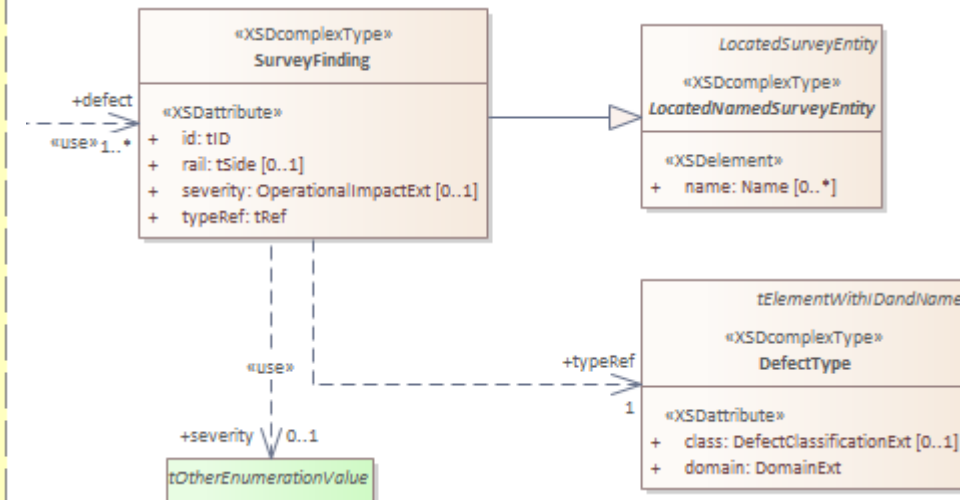
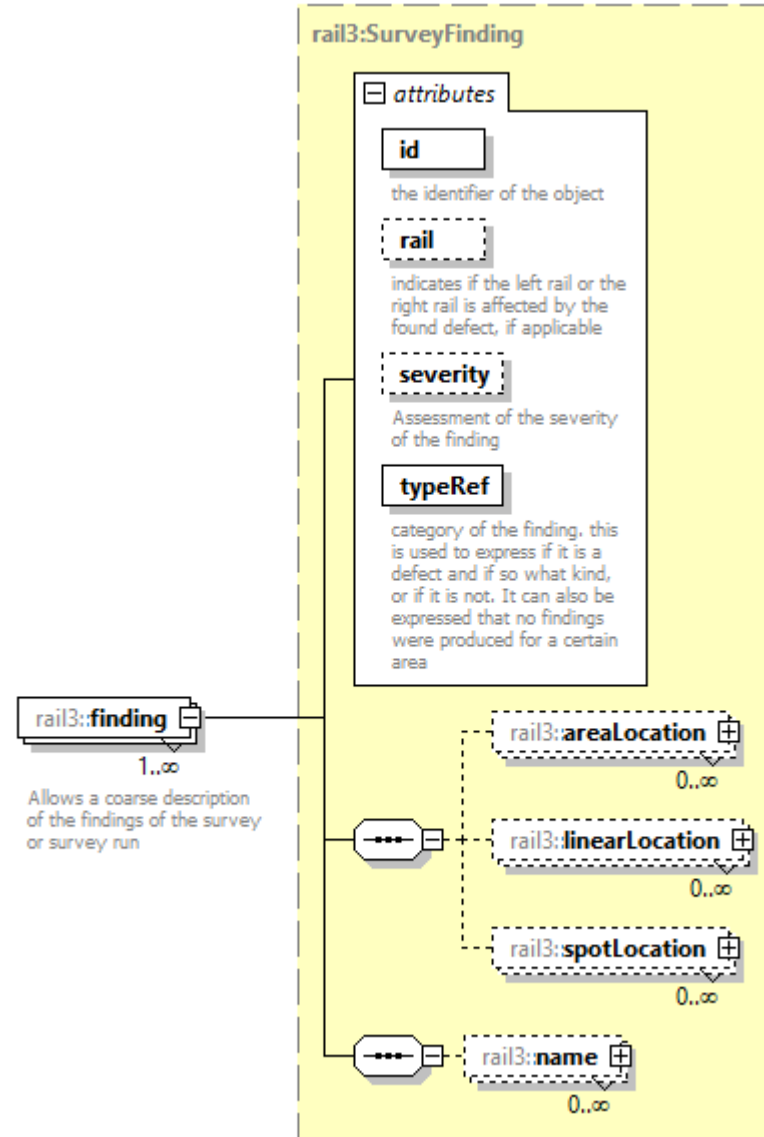

## Findings

- Zusammenfassung der Messfahrt-Ergebnisse
- Ort des Fehlers
- Modellierung erweiterbar
- Klassifikation von Fehlern basierend auf Standards
- Fehler-Schwere (severity) can angegeben werden

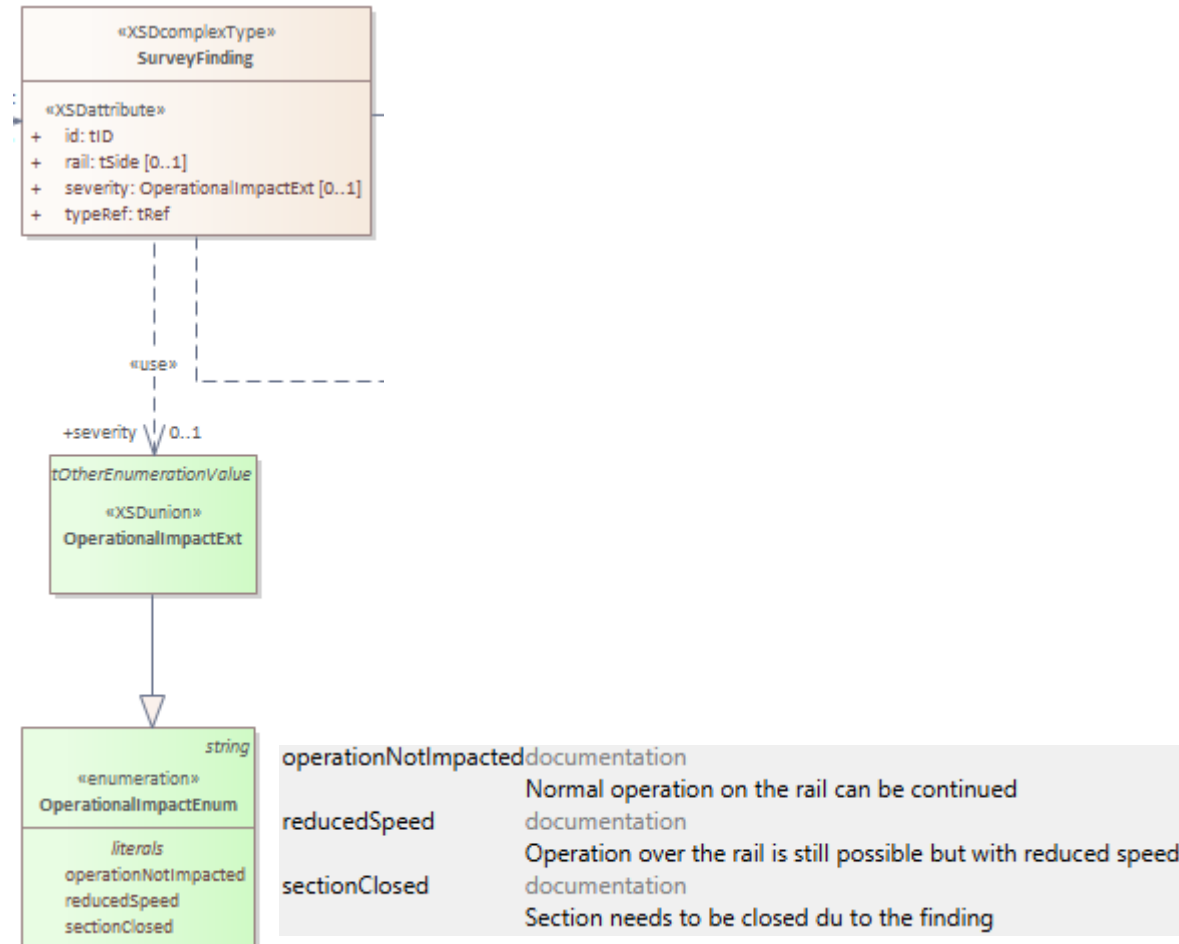

# Survey Data

## Defects

- Referenziert von Findings

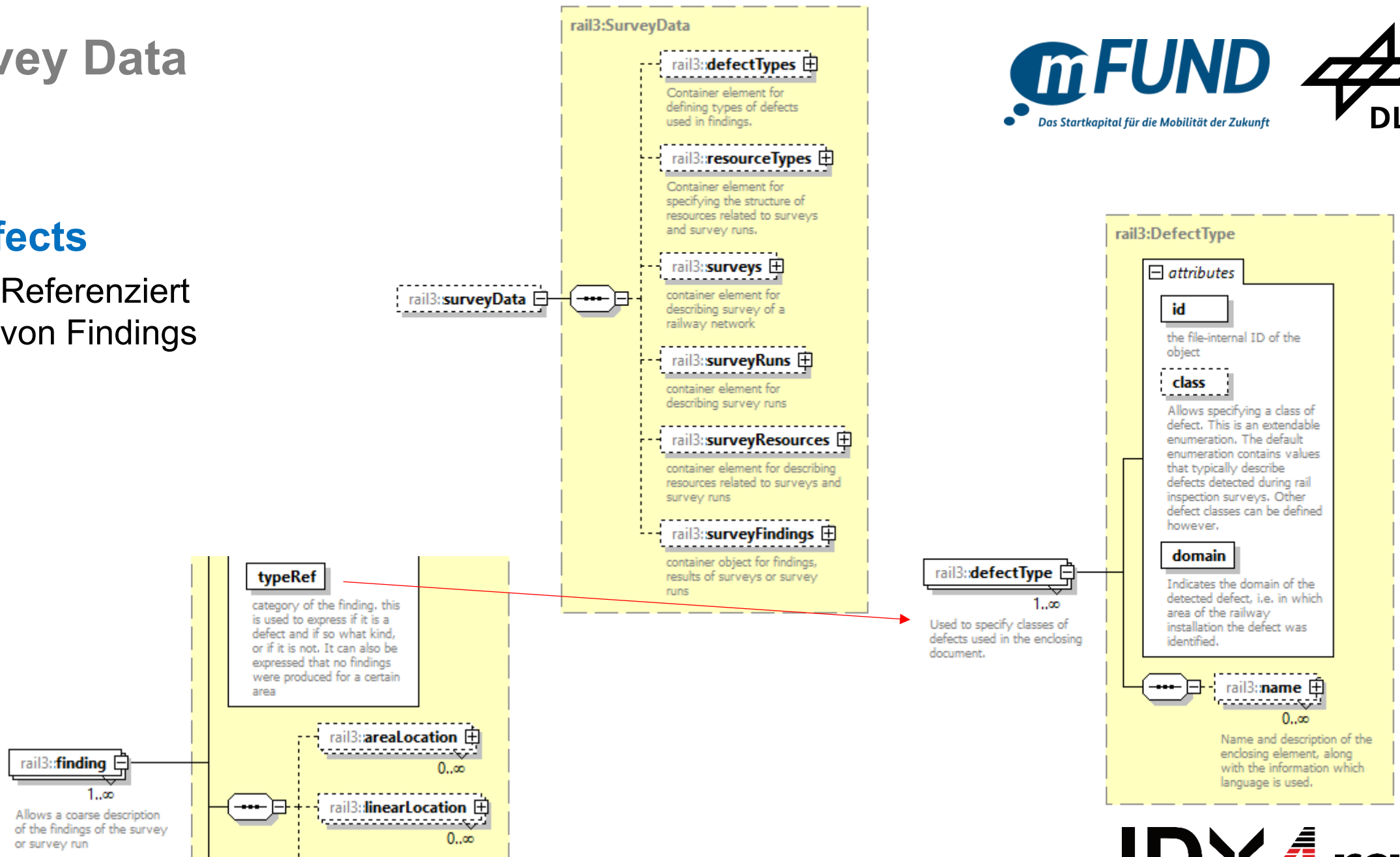

## Defects

- Referenziert von Findings

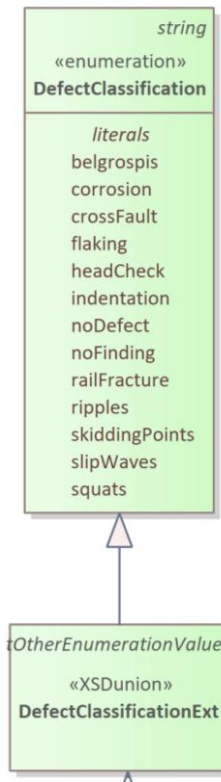

belgrospis	documentation Belgrospis are periodic crack nests at the edge of the road
corrosion	documentation Corrosion of the rail
crossFault	documentation Cross faults are cracks that run perpendicular to the direction of travel
flaking	documentation material breakouts on the running edge of the rail in the longitudinal direction of the rail. Not to be confused with HeadCheck. The continuous, typical crack band of the HeadCheck rail defect is not present.
headCheck	documentation Head checks are fine surface cracks that occur at a distance of 2-7 mm, which occur at a 45° angle to the direction of travel
indentation	documentation Indentations are caused by the rolling over of foreign bodies.
noDefect	documentation No defect was detected
noFinding	documentation No finding available. This value indicates that no measurement was taken, possibly due to equipment failure.
railFracture	documentation Rail fracture refers to the complete failure of the rail so that the track can no longer be used.
ripples	documentation Ripples are quasi-periodic uneven running surfaces in straight tracks and track curves of larger radii with wavelengths of around 2 to 10 cm and depths of 0.01 to 0.4 mm.
skiddingPoints	documentation Skidding points occur when drive wheel sets start to skid during start-up. The resulting heat converts the pearlite in the steel into martensite.
slipWaves	documentation Slip waves or short waves are periodic surface irregularities with lengths of 5 to 30 cm and a depth of 0.1-1 mm.
squats	documentation Squats are depressions on the rail head that are initially visible as small, black dots, but then enlarge and form a semi-circular or V-shaped crack, with the opening of the mould pointing towards the running edge.

- Zusammenfassung Survey Data:
  - Fokus der Modellierung ist auf Erweiterbarkeit
  - Modellierung setzt Fixpunkte im Standard, erlaubt sonst eine sehr offene Umsetzung
  - Importierende Software muss grundlegende Struktur des Messdaten-Konzepts verstehen und umsetzen
  - Messdaten sind nicht Teil des Standards! (zu viel verschiedene Ausprägungen...)
  - Daten werden in externen Ressourcen verlinkt und nicht in der Beschreibungssprache re-modelliert

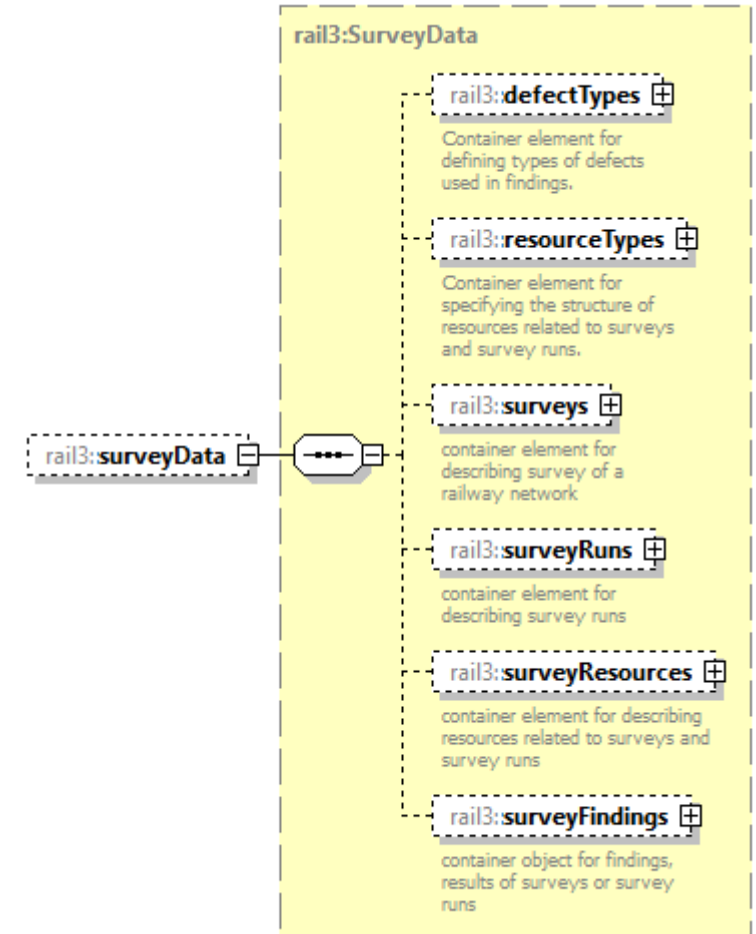

# Maintenance Data

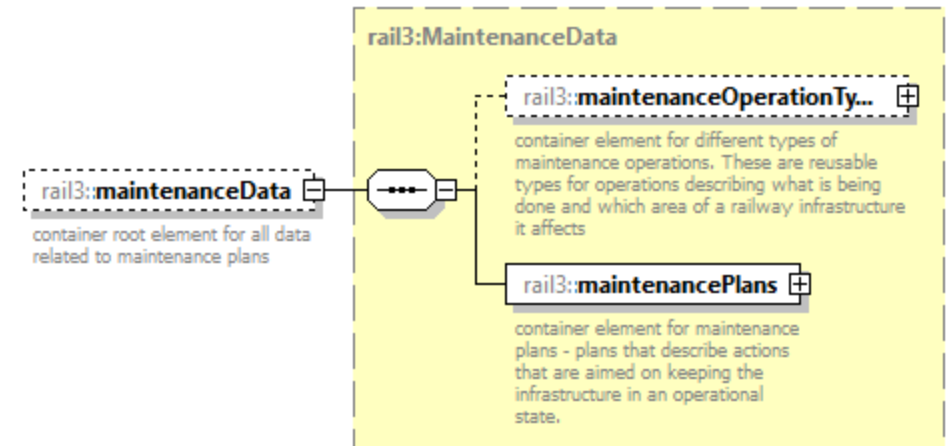
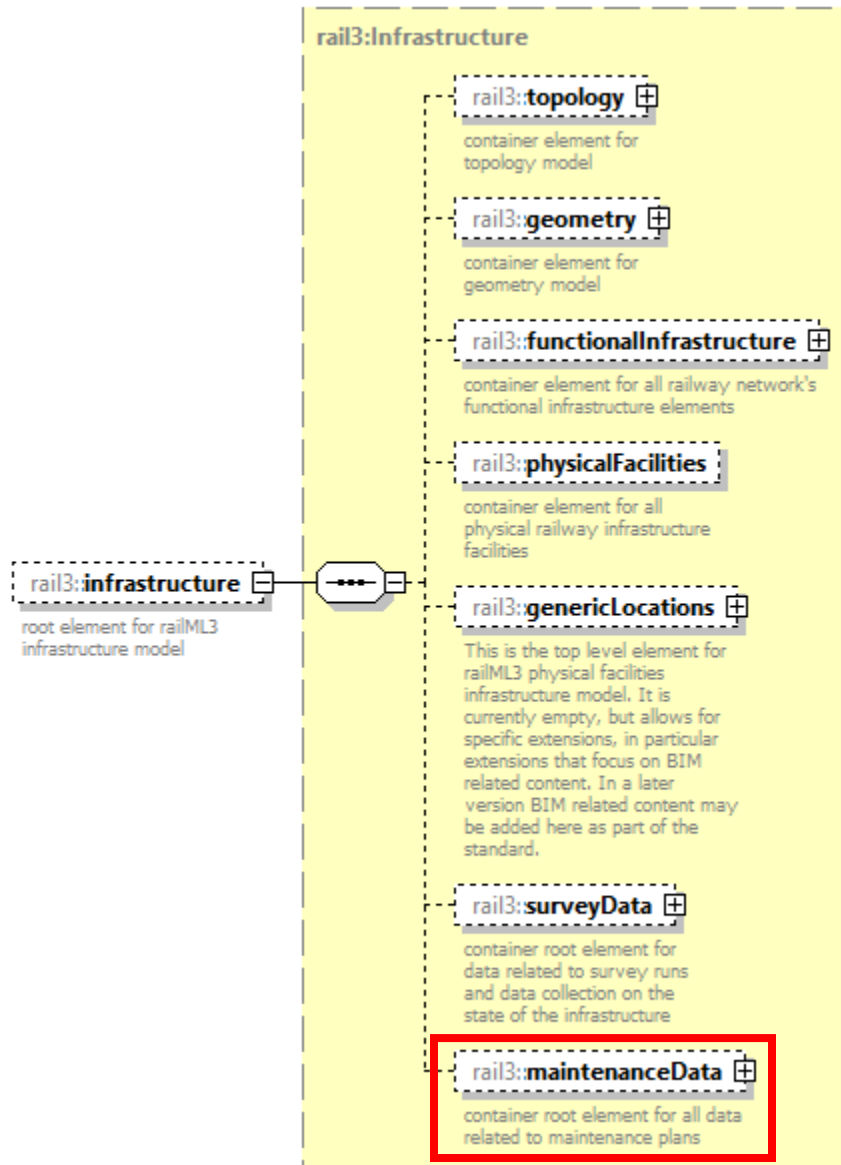

- Instandhaltungsplan

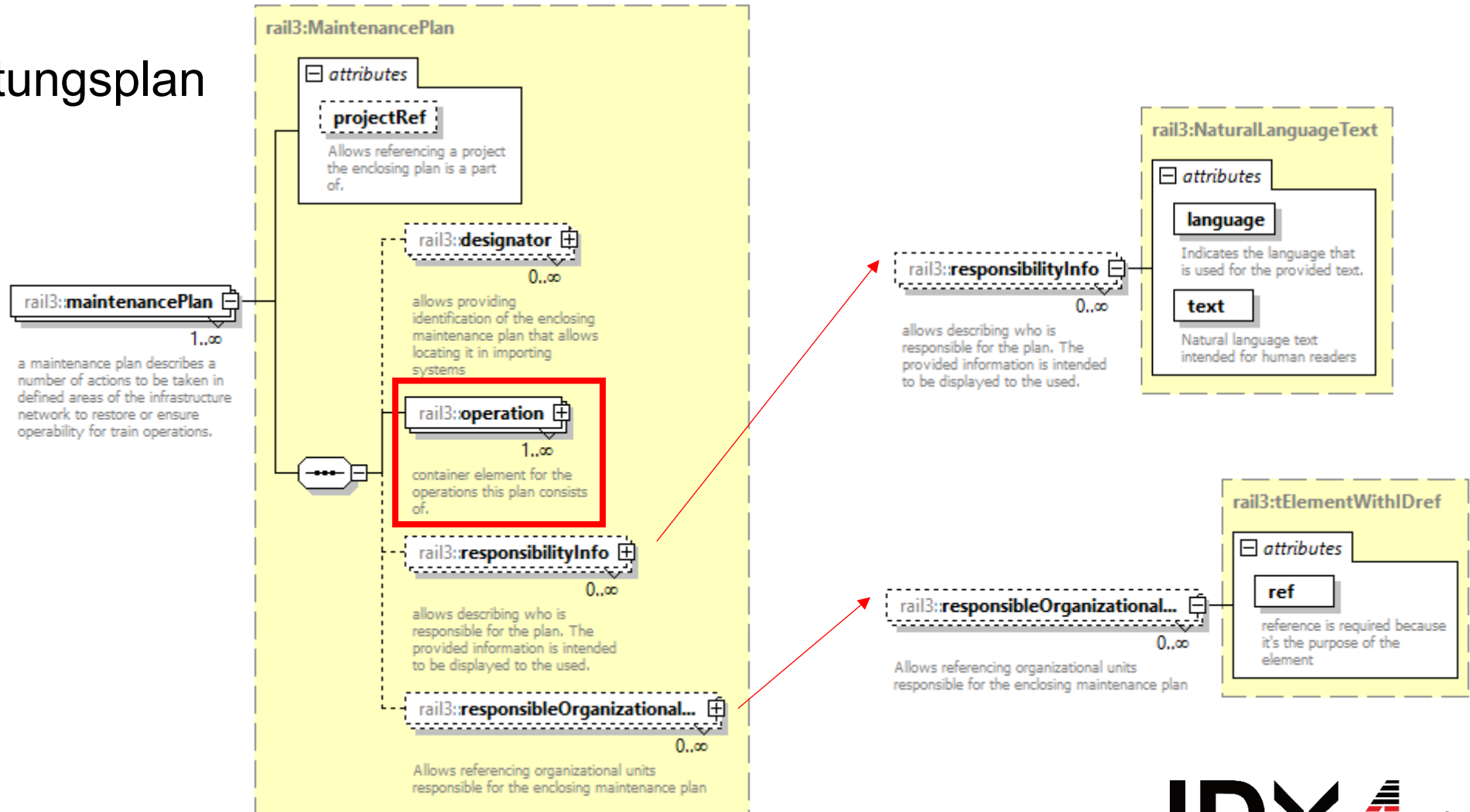

# Maintenance Data

- Instandhaltungsplan
  - Operation = Maßnahme im Plan

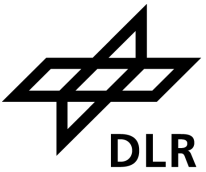
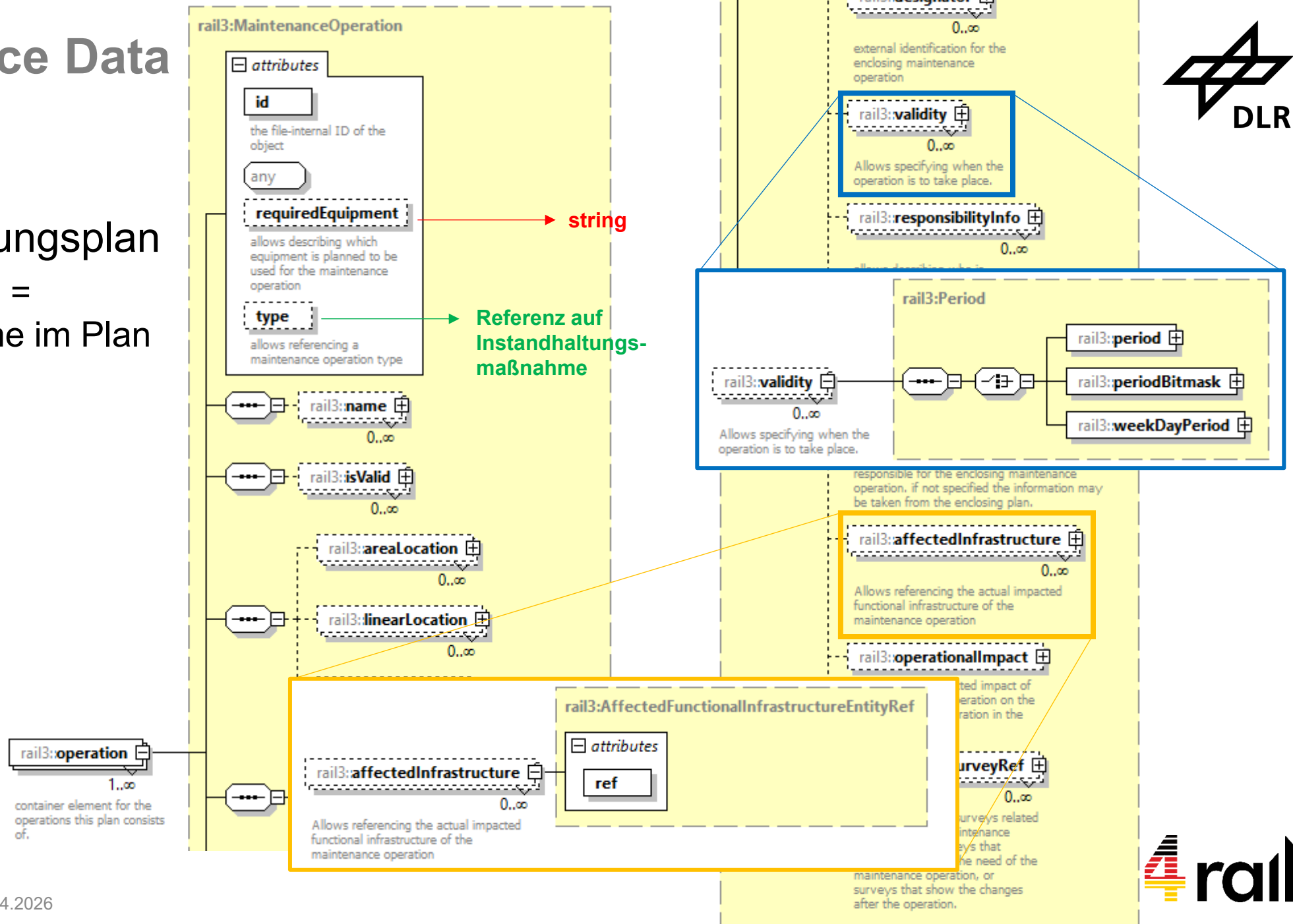

## ■ Instandhaltungsmaßnahme

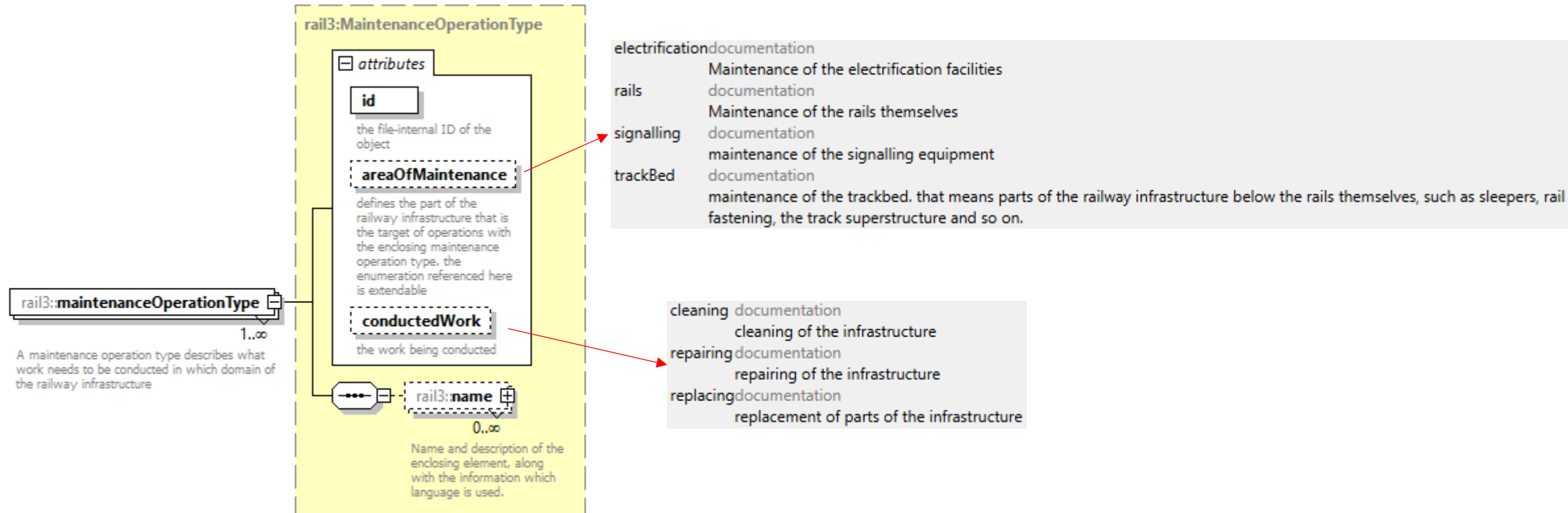

# IDX4RAIL – KONSOLIDIERUNG UND STANDARDISIERUNG DER INFRASTRUKTUR- DATENMODELL- UND –SCHNITTSTELLEN- LANDSCHAFT IM STRASSENBAHN- UND STADTBAHNBEREICH

Gefördert durch:



Bundesministerium  
für Verkehr

aufgrund eines Beschlusses  
des Deutschen Bundestages

Vielen Dank für Ihre Aufmerksamkeit!

Institut für  
Verkehrssystemtechnik  
[www.dlr.de/ts](http://www.dlr.de/ts)

Christian Rahmig  
[christian.rahmig@dlr.de](mailto:christian.rahmig@dlr.de)  
(0531) 295-3461  
Lilienthalplatz 7  
38108 Braunschweig

**IDX**  **rail**

